



РУКОВОДСТВО ПО ЭКСПЛУАТАЦИИ

Индукционные
электродвигатели и
мотор-редукторы
(конические и
цилиндрические)

安全注意事项 SAFETY CAUTIONS

<p>总体 General</p>	<p>请不要在齿轮箱及电机铭牌或产品目录的规格以外使用，以免触电，受伤及损坏装置等。 Please don't use motor out of the range which is clarified in of nameplate of gear box and motor and the specification of product catalogue, avoiding getting an electric shock, hurting or damaging the device.</p> <p>请不要把手指或物品进入齿轮或电机开口部分，以免触电、受伤、发生火灾及损坏装置等。 Please do not put your fingers into the opening part of gear of motor, in order to prevent getting an electric shock, hurting catching a fire or damaging device etc.</p> <p>请不要使用带伤的齿轮箱或电机，以免有可能受伤，发生火灾等。 Please do not use the injured gear head or motor, in order to prevent hurting, catching a fire etc.</p> <p>请不要拆下铭牌。 Please do not put off the nameplate.</p> <p>若客户对产品私自进行改造的，不属于保修范围，本公司不承担任何责任。 If the products are reformed by the customers personally, it no belongs to the guarantee scope, and our company doesn't undertake any responsibility.</p>
<p>搬动/Moving</p>	<p>搬动时，若发生脱落或倾倒，是很危险的，请充分注意。 When you move it, if it shed off or tit to one side, it is very dangerous, please pay more attention.</p>
<p>安装 Assembly</p>	<p>请绝对不要在齿轮箱和电机周围放置可燃物，以免发生火灾。 Please never put the flammable thing near and motor, for fear of a fire.</p> <p>请不要在电机周围放置物品，影响电机通风、冷却，甚至因异常多热而烫伤或发生火灾。 Please do not put the things around motor, otherwise it can effect ventilation and cooling, even burning or catching a fire because of too hot.</p> <p>裸手请不要触碰齿轮及电机轴端部、齿轮部的键槽，以免受伤。 Please do not touch the gear, the motor shaft and the key slot of the gear with naked hand, or you may be hurt.</p> <p>在食品机械等可能发生漏油的装置中，请在安装部分另加一个能盛油的油杯，防止万一漏油对产品有不良的影响。 The device may creating the smoke, such as food machine, please add an oil cup assembly part, to prevent leaking oil which may have a bad effect on the products.</p>
<p>对主机械的连接 Assemble to the main machine</p>	<p>在旋转部分，请设安全罩等，防止受伤。 Please set a safe cover above the revolving part, to prevent being hurt.</p> <p>在与对方机械连接前，请确认旋转方向。若旋转方向不正确，有可能受伤或破坏装置。 Before linking to the other machine, please confirm the revolving direction is not right, it may hurt the gear motor or destroy the device.</p>
<p>配线/Wiring</p>	<p>在测试绝缘电阻时，请不要接触端子，以免触电危险。 Please don't get in touch with terminal, when you measure insure insulated resistance, preventing danger of getting an electric shock.</p>
<p>运转 Operation</p>	<p>请按照接线图或使用说明书实施与电源的连接，以免触电或发生火灾。（无端子箱的，请确实加强连接部分的绝缘） Please link with the electric source according to wire diagram and usage manual, in order to prevent getting an electric shock or catching a fire.(no terminal box, please strengthen the insulation of the connection part surely)</p> <p>对电源电缆和电机引线，请不要过分弯曲、拉伸、夹紧，以免触电危险。 Referring to the electrical source cable and the motor wire, please do not bend, stretch, and clip tightly excessively, in order to prevent getting an electric shock.</p> <p>接地端子应牢固接地，以免触电危险。务必使用符合铭牌要求的电源，以免烧毁电机、发生火灾。 The terminal box connecting to the ground must be firm, in order to prevent getting an electric shock.</p> <p>Please adopt the electrical source according to the nameplate, to avoid burning the motor and catching a fire.</p>
<p>日常检查保养 The daily check and maintain</p>	<p>在运转中，绝对不要接近或接触旋转物体（轴等）。有卷入受伤时，请马上切断电源开关，及时处理。 When operating, do not get close to or touch the revolving parts(shaft). If something or somebody engulfs or hurts, Please turn off the electrical power switch right and handle at once.</p> <p>停电时，请务必切断电源开关，防止来电后伤人或破坏装置。 please turn off the electrical source switch when electricity stops, in order to prevent hurting the person and damaging the device.</p> <p>请注意：带有热保护的电机，当电机温度异常时会自动切断电源，当电机温度下降到一定值时，电机自动恢复工作。 (注：电机在没有烧坏的情况下，会自动复原) Please note, motor with the thermal protector, when temperature of the motor is unusual, it will turn off the electrical source automatically, when the temperature of the motor fall down to a fixed data, the motor can work automatically. (Note: when the motor is not burned-not, the motor can work automatically.)</p> <p>在平常时，保持电机在正常的工作环境工作运转。（特殊型号除外） In daily, you should keep the motor operating in the normal work environment.(Except the special model)</p> <p>检查时，请绝对不要接触旋转物体（轴等）。有可能被卷入、受伤。 While checking, please do not get close to or touch the revolving parts(shaft). Something or somebody may engulf of hurt.</p>
<p>接受货物时检查 Receiving confirm</p>	<p>请确认现货是否和订货一样。选择错误的产品，有可能导致电机受损或破坏装置等。 Please confirm if it is the right one with the order when receiving. Choosing wrong probably leads to damage of motor of damage the device and etc.</p>

型号的阅读方法 PRODUCT NUMBER CODE

电动机 Motor

5 I K 40 R GN - C T
① ② ③ ④ ⑤ ⑥ ⑦ ⑧

①	电动机的尺寸 Motor Frame Size	0: 42mm 2: 60mm 3: 70mm 4: 80mm 5: 90mm 6: 104mm
②	类型名称 Motor Type I : 感应电动机 Induction Motor R : 可逆电动机 Reversible Motor T : 转矩电动机 Torque Motor	
③	系列名称 Series	K : K系列 K Series
④	输出功率 Output Power (W)	(例 Example)40 : 40W
⑤	R : 表示带调速电动机; 无 : 表示未带 The Suffix "R" After The Output Power Means Speed Adjustable Motor. 转轴形状 Motor Shaft Type	
⑥	GN : GN型齿轮轴 GN Type : Pinion Shaft GU : GU型齿轮轴 GU Type : Pinion Shaft A : 圆轴型 Round Shaft A1 : 键槽型 Keyway	
⑦	电源电压·极数 Voltage·Poles A : 单相 Single-Phase 110V50/60Hz 4P H : 单相 Single-Phase 220/230V60Hz 4P B : 单相 Single-Phase 110V50Hz 2P S : 三相 Three-Phase 200/220/230V50/60Hz 4P C : 单相 Single-Phase 220/230V50Hz 4P S3 : 三相 Three-Phase 380/400/415V50/60Hz 4P D : 单相 Single-Phase 220V50Hz 2P T : 三相 Three-Phase 200/220/230V50/60Hz 2P E : 单相 Single-Phase 110V/120V60Hz 4P T3 : 三相 Three-Phase 380/400/415V50/60Hz 2P	
⑧	T : 带端子箱型 Terminal Box Type F : 带风扇 W/Fan FF : 带强制风扇 W/Forced Fan M : 无励磁动作型电磁制动电动机 Power Off Activated Type Electromagnetic Brake Motor	

减速器型号说明 Description Of Reducer Model

5 GN 50 K RH
① ② ③ ④ ⑤

①	减速器安装尺寸 Gearhead Frame Size	0: 42mm 2: 60mm 3: 70mm 4: 80mm 5: 90mm 6: 104mm
②	类型 Type Of Pinion	GN : GN型齿轮轴 GN Type Gear GU : GU型齿轮轴 GU Type Gear
③	减速比 Gear Ratio	(例 e.g) 50 : 减速比 Gear Ratio Of 1 : 50 10x(仅限减速器1 : 10的中间减速比 10x Denotes The Decimal Gearhead Of Ratio 1 : 10
④	轴承种类 Bearing Type	K : 滚珠轴承(对GU型方箱体标注为KB) Bearing(Make KB for Type GU Square Case)
⑤	输出种类 Type Of Output Shaft	RH : 蜗轮蜗杆空心轴输出 Hollow Worm Shaft RA : 蜗轮蜗杆实心轴输出 Worm Output Shaft RC : 弧锥齿空心轴输出 Spiral Bevel Hollow Shaft RT : 弧锥齿实心轴输出 Spiral Bevel Output Shaft

如 : 电机配平行轴减速器时第5项省略, 如配直角减速器时第4项省略。

Note: If the motor assembly with parallel gear box pls cancel item no 5, if assembly with right angle gear box pls cancel item no 4.

电动机的一般规格 GENERAL SPECIFICATIONS OF MOTORS

3W~200W型、2极·高速型 6W~150W、2P·High Speed

项目 Item	规格 Specifications
绝缘电阻 Insulation Resistance	于常温·常湿下的电动机额定运行后，以DC500V电阻表测量线圈·外壳间时，测量值为100MΩ以上 In the circumstance of normal temperature and humidity, the resistance can be up to 100MΩ, measured DC 500v insulation resistance measurer between the motor wiring and motor shell while the motor is working.
绝缘耐压 Insulation Voltage	于常温·常湿下电动机额定运行后，在线圈·外壳间施加一分钟50Hz或60Hz、1.5kV（三相400V为2kV）的电压，亦无异常 In the circumstance of normal temperature and humidity, there will be no problem supplying the power of 1.5kv(three phase400v: 2kv) at 50/60Hz between the metal wiring and motor shell for 1 minute while the motor is working.
温度上升 Temperature Rise	在装上减速机或同等散热板※并于常温·常湿下进行额定运行时，以电阻法测定其线圈温度上升值为80℃以下（三相型为70℃以下） The temperature rise of winding are 80°C or less measured by the resistance change method after rated motor operation under normal ambient temperature and humidity, with connecting a gearhead or equivalent heat radiation plate※.
绝缘等级 Insulation Class	UL/CSA规格: A种 (105°C)、EN规格: B种 (130°C) UL/CSA Standards: Class A(105°C) EN Standards: Class B(130°C)
过热保护装置 Overheat Protection	内藏热保护装置（自动复位型） B种（开放: 120°C±5°C、75°C±15°C） F种（开放: 145°C±5°C、100°C±15°C） Thermal protector inside (automatic return) Class B (opening: 120°C±5°C、75°C±15°C) Class F (opening: 145°C±5°C、100°C±15°C)
使用环境温度 Ambient Temperature	单相100V、三相200V: -10~+50°C（无结冰） 其他电压: -10~+40°C（无结冰） Single-Phase100VAC、Three-Phase200VAC: -10~+50°C(NonFreezing) Others: -10~+40°C(NonFreezing)
使用环境湿度 Ambient Humidity	85%以下（无结露） ≤85% (Noncondensing)
保护等级 Protection Class	导线型 Lead wire type:IP20 带端子箱型: Terminal Box Type 单相Single-phase 100V50/60HZ、110/120V60HZ、220/230V50HZ、220/230V60HZ 25W-180W Type: IP54（不包括圆轴安装面 Excluding the installation surface of the round shaft type） 三相Three-phase 200/220/230V50/60HZ、380/400/415V50/60HZ 25W-180W Type: IP54（不包括圆轴安装面 Excluding the installation surface of the round shaft type）

散热板尺寸（材质：铝）Heat Radiation Plate(Material: Aluminum)

电动类型 Motor Type	尺寸Size	厚度Thickness (mm)
3W Type	80X80	5
6W Type	115X115	
15W Type	125X125	
25W（2极·高速4IK40型、4IK60型）(2P-High-Speed 4IK40 Type, 4IK60 Type)	135X135	
40W、60W Type	165X165	
60W、90W、120W Type （2极·高速5IK150型）(2P-High-Speed 5IK150 Type)	200X200	
120W、140W、200W Type	230X230	

电动机的特性 MOTOR FEATURES

■ 感应电动机的特性 Induction Motor Features

- 1、一般来说，微型感应电动机所指的是感应运转型感应电动机。这种电动机不只在启动时，在运转当中也使用电磁线圈和电容器。虽然启动转矩不是很大，但其结构简单，信赖度高，效率也比较高，可连续运转。
Generally, Micro Induction Motor refers to the motor rotated by the induction. Induction Motor relies on capacitor and electromagnetism when starting and rotating. Though its starting torque is not very high, it has a simple structure, high efficiency and can rotate continue.
- 2、单相电动机运转时，产生与运转方向逆方向的转矩，因此不可能在短时间内改变方向。请在电动机完全停止以后，再转换其运转方向。
The single-phase motor have a reverse direction with the rotating's when operated. Pls change the direction of single-phase motor rotation only after bring the motor to a stop.
- 3、三相电动机以三相电源驱动感应电动机，其效率很高，启动力矩也比较大，信赖度高。
Three-phase motor relies on three-phase supply. It has a high efficiency and can get a high starting torque.

■ 可逆电动机的特性 Reversible Motor Features

- 1、可逆电动机，在电动机后部设有简易制动器，是适用于短时间内频繁正反转用途的电机。简易制动器的构造，如图1所示，带弹簧压力的制动柱作用在转动的制动盘上并保持连续压力。可逆电动机的简易制动器如下作用：
Reversible Motor has a friction brake at the back of the motor body, which is designed for applications where reversal of direction is frequently required. For the friction brake, pls check Draw 1. The damp with spring impacts the rotating brake disk and supplies with continuous press. The functions of the friction brake are as following:

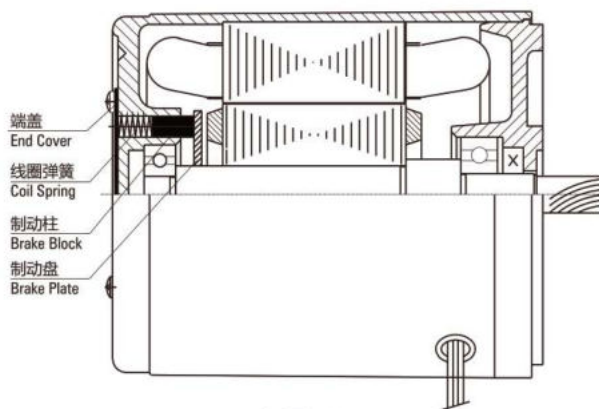

如图 /Fig.1

- ① 加摩擦负荷，提高瞬间可逆特性。
With friction load, increasing the instant reversal.
 - ② 缩小超程。
Shorten over-run.
 - ③ 具有某种程度的保持力矩。（额定力矩10%左右）
Keep the torque in some way. (about 10% of the rated torque)
- 2、简易制动器的保持力矩及超程表示在表1，但随着运转时间的长短或温度高低，也会有变化，仅供参考。且初期使用，其保持力矩比表1的值低的情况也会发生，请注意。
The keeping torque or more of the friction brake and over-run are listed in the table 1. It is only for reference. As it will change according to the rotating period as well as the temperature. Pls also note that the torque may be a little lower than the one listed in the table when being operated initially.
 - 3、可逆电动机和感应电动机相同，都是电容动转单相电机，转矩力矩特性与感应电机特性相同。但是，为了提高瞬间可逆特性，如图2所示，设计为加大启动力矩。受此影响，加大了输入的损耗，温升比感应电动机高，因此，时间定额为30分钟。特性表中的额定力矩，启动力矩，电流特性等是在电机上装上有制动柱状态下的特性值。
The Reversible Motor, like Induction Motor, is started by the capacitor and has a same torque characteristic with the Induction Motor. But the Reversible Motor is designed with a higher starting torque to increase the instant reversal features. Pls check drawing 2.

■ 表1.保持力矩和超程 Table 1. Keep Torque And Over-run

相数Phase	尺寸 Size	输出功率 Output W	电机型号 Motor Model	保持力矩 Keep Torque		超程 Over-run 圈数Cycles
	mm			N.cm	Kgf.cm	
单相 Sing-Phase	60	6	2RK6	0.5	0.05	4
	70	15	3RK15	1.3	0.13	5
	80	25	4RK25	1.5	0.14	5
	90	40	5RK40	4.0	0.40	6
		60	5RK60			
		90	5RK90			
	120	5RK120				

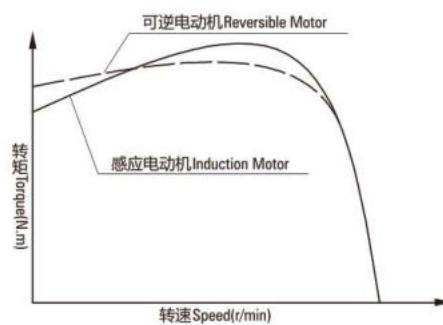

如图 /Fig.2

■ 无励磁动作型电磁制动电动机特性 Power Off Activated Type Electromagnetic Brake Motor Features

1、构造及运行原理 Structure and Operation Principle

图3是带电磁制动的电机的构造图。本公司生产的电磁制动电动机是无励磁动作型，在线圈上施加电压，则立即吸引被弹簧压着的可动衔铁，在可动衔铁和制动衬垫之间产生间隙，使电机处于运转状态。一旦线圈电压被切断，在弹簧力的作用下，可动衔铁压向制动衬垫，产生制动力，电机停止。

Table 3 is the structure for the Electromagnetic Brake Motor. We produce the Power Off Activated Type. Exerting the voltage on the winding, it will magnetize the armature pressed by the spring. The motor will be in a stage of rotating, when there is a backlash between the armature and brake rim. Once the winding voltage is cut down, under the influence of spring, the armature press the brake rim, which will create a brake force. Then the motor gets to a stop.

2、电磁制动器的特点 The Characteristics of the Electromagnetic Brake

该制动器是交流无励磁动作型电磁制动器，与电机直接连接。在切断电源的同时，即瞬间停止，保持负荷。保持力矩0.05~2.0N.m（参照表2）。由于是电源切断时的保持力动作型，故最适合于作为无意间切断电源时的安全制动器使用。电磁可以进行频繁的瞬间正反转。简单的切换，1分钟内可停止6次。但是时间必须确保3秒以上。

It is an AC Power Off Activated Type Electromagnetic Brake which is connected directly with the motor. It will get to a blink stop and keep load when the supply is power off. It will keep the torque between 0.05-2.0Nm. It is especially suitable for the safety brake in the circumstance of unconsciously power off. The electromagnetic can change its direction frequently. It can be stopped 6 times in a minute. But be sure that it lasts for 3 seconds or more.

电机和制动器可以使用同一个电源。制动器内设置整流回路，可和电机使用同一个交流电源。

After we set a commutating loop in the brake, it can share the power supply with the motor.

※这个数值是标准的，根据使用条件的不同，以这个频度连续使用不能进行制动器操作的情况也有，实际使用时，必须在电机表面温度为90度以下的条件下使用。

※The value is standard. It will be change in different condition. When actually used, be sure to make the surface temperature of the motor less than 90 °C.

3、启动时间，制动时间的特性 The Features for the Starting Time and Brake Time

电磁制动电机的启动时间是电机自身的启动时间加上电磁制动器的释放时间，制动时间是从电源切断开始至电机完全停止的时间。电磁制动电机的超程、启动时间、制动时间应用场合而不同。

The starting time means the time for the motor's starting time plus the electromagnetic brake release time. The brake time means the time from power cut off to the time of motor completely stop. The over-run, starting time and brake time will be different according to the different applications.

■ 表2.电磁制动部分（无励磁动作型） Electromagnetic Brake(Power Off Activated Type)

相数 Phase	基座 尺寸 MM	输出 功率 Output W	电压 Voltage V	频率 Frequency Hz	电流 Current A	输入 功率 Input W	保持力矩 Keep Torque		超程 Over-run 圈数Cycles
							N.cm	Kgf.cm	
1Phase	70	15	110 120 220 230	50/60	0.091	8.2	0.5	50	3.5
	80	25							
	90	40							
		60							
		90							
		120							
	100	120			0.111	10.0	1.0	100	
		140							
		200							
	3Phase	60			6	220~230	50/60	0.073	
70		15	380~415	0.037	6.6	0.25		25	
80		25	200~230 380~415	0.091	8.2	0.5		50	
		40		0.046	8.2	0.5		50	
		60		0.111	10.0	1.0		100	
		90							
100		120	200~230 380~415	0.056	10.0	1.0		100	
		120							
		140							
		200	200~230 380~415						0.144
				0.144	13.0	2.0	200		

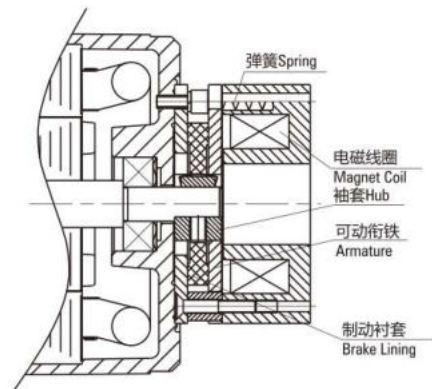

如图 /Fig.3

■ 调速电机特性 The Features Of The Speed Control Motor

1、是控制器和电机组合的单元产品，由于电机和控制品只需一次连接，故不需要单独接线。速度调节由安装在外部的电位器便可简单进行。在控制器上安装了速度控制器回路、电机用的电容，速度设定器等。其中单元式速度控制器无瞬间停止功能。

It is a unit of the controller and motor. It only needs to connect one time. The speed can be easily adjusted by the potentiometer. The controller is fixed with speed-control loop, capacitor, speed enactment and etc. There is no function of instant stop in the unit.

2、用控制器的速度调节器进行速度调节。可以在50Hz为90~1400的r/min，60Hz为90~1700r/min范围内，调节电机的速度。

The controller can make the speed variable between 90-1350rpm at 50 Hz and 90-1650rpm at 60Hz.

3、电机不允许长时间在低转速下运行，以免电机过热。

Please don't run motor at low speed for long time avoiding overheat.

感应电动机 INDUCTION MOTORS

■ 3W □ 42mm



规格 Specs 连续额定 Continuous Rating

型号Model · 类型 Type 导线型 Lead Wire Type		输出功率 Output power W	电压 Voltage V	频率 Frequency Hz	电流 Current A	启动转矩 Starting Torque mN.m	额定转矩 Rated Torque mN.m	额定转速 Rated Speed r/min	电容器容量 Capacitor μF
齿轮轴型 Pinion Shaft	圆轴型 Round Shaft								
0IK3GN-B	0IK3A-B	3	1ph 110	50	0.120	5	11	2500	1.5
				60	0.130		10	3000	
0IK3GN-D	0IK3A-D	3	1ph 220	50	0.060	5	11	2500	0.35
				60	0.064		10	3000	

● 各种安全规格以电动机铭牌上的型号名取得认证。
When the motor is approved under various safety standards, the model name on the nameplate is the approved model name.

种类 Type

● 电动机 Motor

机型 Type	型号Model	
	齿轮轴型 Pinion Shaft	圆轴型 Round Shaft
导线型 Lead Wire Type	0IK3GN-B	0IK3A-B
	0IK3GN-D	0IK3A-D

● 平行轴减速器 (另售) Parallel Shaft Gearhead (Sold Separately)

减速器种类 Gearhead Type	减速器型号 Gearhead Model	减速比 Gear Ratio
长寿命●低噪音 Long Life ● Low Noise	0GN□K	3、3.6、5、6、7.5、9、 12.5、15、18、25、30、 36、50、60

● 减速器型号的□中为减速比的数值
Enter the gear ratio in the box (□) within the model name

■ 装有减速器时的容许转矩 Gear Motor-Torque Table

- 减速器另售·中间减速器无另售品。
Gearhead are sold separately. Decimal gearheads are not available.
- 减速品型号的□中为减速比的数值。
Enter the gear ratio in the box(□) within the model name.
- □色表示与电动机同一方向运转，其他则为相反方向。
The colored background □ indicates the same rotating direction of the motor while the rotating direction of others are opposite.
- 转速是以电动机的同步转速（2极型 50Hz：3000r/min、60Hz：3600r/min）为基准除以减速比而算出来的数值。
实际转速将随负载大小变化所示数值减少2%~33%左右。
The speed is calculated by dividing the motor's synchronous speed(2P Type 50Hz：3000r/min、60Hz：3600r/min) by the gear ratio. The actual speed is 2%~33% less than the displayed value, depending on the size of the load.

■ 容许力矩单位 Allowance Torque Unit：上段 Upside (N.m) /下段 Belowside (kgf.cm)

类型 Type 电动机/减速机 Motor/Gearhead	减速比 Gear Ratio		3	3.6	5	6	7.5	9	12.5	15	18	25	30	36	50	60
	转速 Speed r/min															
OIK3GN-B OIK3GN-D	OGN□K	50Hz	0.027	0.032	0.045	0.053	0.067	0.080	0.10	0.12	0.14	0.18	0.22	0.26	0.36	0.44
		60Hz	0.28	0.33	0.46	0.54	0.68	0.82	1.02	1.22	1.43	1.84	2.24	2.65	3.67	4.49
		50Hz	0.024	0.029	0.041	0.049	0.061	0.073	0.091	0.1	0.13	0.17	0.20	0.24	0.33	0.40
		60Hz	0.24	0.30	0.42	0.50	0.62	0.74	0.93	1.12	1.33	1.73	2.04	2.45	3.67	4.08

■ 容许悬挂负载·容许轴向负载 To Allow The Hoisting Of The Load Allow Axial Load

电动机 (圆轴型) →272页

Motor(Round Shaft) →P272

减速机→272页

Gearhead→P272

■ 减速机的容许负载惯性惯量 J Permissible Load Inertia J For Gearhead

→272页→P272

■ 外形图 (单位 mm) Dimensions(Unit mm)

减速机附有安装用螺丝 Mounting screws are included with gearhead.

● 导线型 Lead Wiring Type

重量 Weight：电动机 Motor：0.3kg

减速机 Gearhead：0.2kg

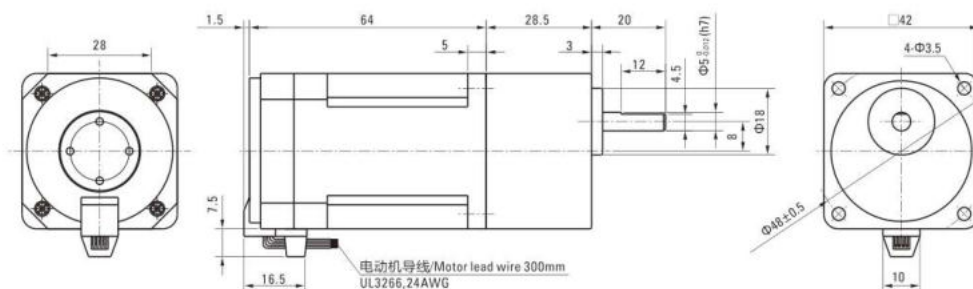

● 圆轴型的转轴部分 Shaft Section Of Round Shaft Type

除重量及轴部外电动机外形与齿轮轴型相同。
Excluding weight and the shaft section motor shape are the same as those of the pinion shaft type.

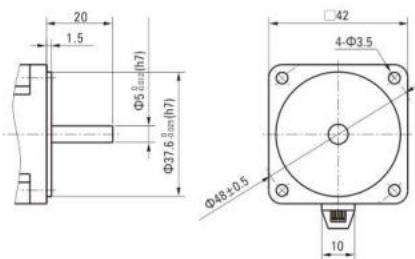

■ 电容器外形尺寸 Formal Dimension Of Capacitor

型号Model		电容器型号 Capacitor Model	L	W	H
齿轮轴型 Pinion Shaft	圆轴型 Round Shaft				
OIK3GN-B	OIK3A-B	ZD15CFAUL	36	12.5	24
OIK3GN-D	OIK3A-D	ZD035CFAUL	26	8	17

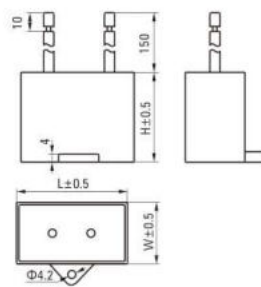

- 常规电容器出线为引线,也可根据客户要求配置插片式187#
Note: Conventional capacitor is a lead wire type. Inserted 187# is optional

■ 连接图 Wiring Diagram

- 运转方向指从电动机轴看来的方向。CW表示顺时针方向,CCW表示逆时针方向。
The direction of motor rotation is as viewed from the shaft end of motor. CW represents the clockwise direction, while CCW represents the counterclockwise direction.
- 表中所记品名为齿轮轴型,圆轴型亦同。
Name indicated in the list is pinion shaft type, also valid for the equivalent round shaft type.

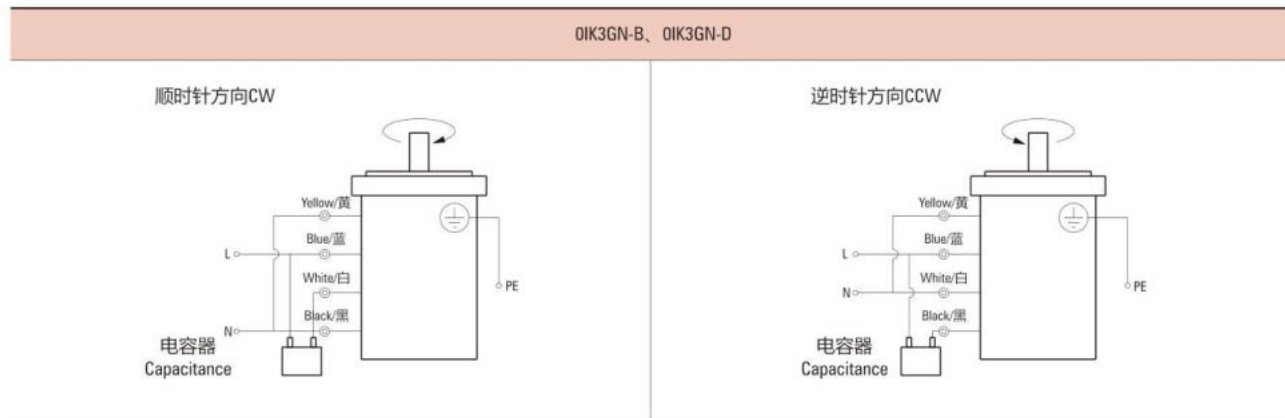

请注意 Note:

单相电动机运转方向的转换应在电动机停止后进行。
Change the direction of single-phase motor rotation only after bring the motor to a stop.
若在电动机运转时转换运转方向,可能发生无法转换运转方向或须费时较久的情况。
If an attempt is made to change the direction of rotation while the motor is rotating, motor may ignore reversing command or change its direction of rotation after some delay.

感应电动机 INDUCTION MOTORS

■ 6W □ 60mm



规格 Specs 连续额定 Continuous Rating

型号Model · 类型 Type 导线型 Lead Wire Type		输出功率 Output power W	电压 Voltage V	频率 Frequency Hz	电流 Current A	启动转矩 Starting Torque mN.m	额定转矩 Rated Torque mN.m	额定转速 Rated Speed r/min	电容器容量 Capacitor μF
齿轮轴型 Pinion Shaft	圆轴型 Round Shaft								
2IK6GN-A	2IK6A-A	6	1ph 100	50	0.240	55	48	1200	3.5
				60	0.250	50	40	1450	
2IK6GN-E	2IK6A-E	6	1ph 110 1ph 120	60	0.160	40	40	1450	2
					0.180				
2IK6GN-C	2IK6A-C	6	1ph 220 1ph 230	50	0.130	50	48	1200	0.8
					0.140		40	1450	
2IK6GN-H	2IK6A-H	6	1ph 220 1ph 230	60	0.130	55	40	1450	-
					0.140				
2IK6GN-S	2IK6A-S	6	3ph 220	50	0.076	85	48	1200	-
				60	0.065	70	40	1450	

- 各种安全规格以电动机铭牌上的型号名取得认证。
When the motor is approved under various safety standards, the model name on the nameplate is the approved model name.
- 注：“-A”型号中电压为110V时，配置电容器容量以实际铭牌为准。
Note:“-A” it means the voltage 110v,the assembly capacitor vaule it is according the label.

种类 Type

● 电动机 Motor

机型 Type	型号Model	
	齿轮轴型 Pinion Shaft	圆轴型 Round Shaft
导线型 Lead Wire Type	2IK6GN-A	2IK6A-A
	2IK6GN-E	2IK6A-E
	2IK6GN-C	2IK6A-C
	2IK6GN-H	2IK6A-H
	2IK6GN-S	2IK6A-S

● 平行轴减速器（另售） Parallel Shaft Gearhead (Sold Separately)

减速器种类 Gearhead Type	减速器型号 Gearhead Model	减速比 Gear Ratio
长寿命●低噪音 Long Life ● Low Noise	2GN□K	3、3.6、5、6、7.5、9、12.5、15、18、25、30、36、50、60、75、90、100、120、150、180、200
	2GN10XK (中间减速器 Decimal Gearhead)	

- 减速器型号的□中为减速比的数值
Enter the gear ratio in the box (□) within the model name

■ 装有减速器时的容许转矩 Gear Motor-Torque Table

- 减速器另售·中间减速器另售。
Gearhead and mid-gearbox can be sold separately.
- 减速品型号的□中为减速比的数值。
Enter the gear ratio in the box(□) within the model name.
- □色表示与电动机同一方向运转，其他则为相反方向。
The colored background □ indicates the same rotating direction of the motor while the rotating direction of others are opposite.
- 转速是以电动机的同步转速（50Hz：1500r/min、60Hz：1800r/min）为基准除以减速比而算出来的数值。实际转速将随负载大小变化所示数值减少2%~20%左右。
The speed is calculated by dividing the motor's synchronous speed (50Hz：1500r/min、60Hz：1800r/min) by the gear ratio. The actual speed is 2%~20% less than the displayed value, depending on the size of the load.
- 希望以大于下表的减速比进行进一步减速时，可在电动机与减速机之间安装减速比为10的中间减速器。这时的容许转矩为3N·m。
To reduce the speed beyond the gear ratio in the table, attach a decimal gearhead(gear ratio:10)between the gearhead and motor. In that case, the permissible torque is 3 N·m.

■ 容许力矩单位 Allowance Torque Unit：上段 Upside (N.m) /下段 Belowside (kgf.cm)

类型 Type 电动机/减速机 Motor/Gearhead	减速比 Gear Ratio		3	3.6	5	6	7.5	9	12.5	15	18	25	30	36	50	60	75	90	100	120	150	180	200
	转速 Speed r/min	50Hz	500	417	300	250	200	166	120	100	83	60	50	41	30	25	20	16	15	12.5	10	8.3	7.5
2IK6GN-A 2IK6GN-E 2IK6GN-C 2IK6GN-H 2IK6GN-S	2GN□K	50Hz	0.12	0.14	0.19	0.23	0.29	0.35	0.49	0.58	0.70	0.88	1.1	1.3	1.6	1.9	2.4	2.9	3	3	3	3	3
		60Hz	1.22	1.43	1.94	2.35	2.96	3.57	5.0	5.92	7.14	8.98	11.2	13.3	16.3	19.4	24.5	29.6	30	30	30	30	30
	60Hz	50Hz	0.10	0.12	0.16	0.19	0.24	0.29	0.41	0.49	0.58	0.73	0.88	1.1	1.3	1.6	2.0	2.4	2.6	3	3	3	3
		60Hz	1.02	1.22	1.63	1.94	2.45	2.96	4.18	5.0	5.92	7.45	8.98	11.2	13.3	16.3	20.4	24.5	26.5	30	30	30	30

■ 容许悬挂负载·容许轴向负载 To Allow The Hoisting Of The Load Allow Axial Load

电动机（圆轴型）→272页

Motor(Round Shaft) →P272

减速机→272页

Gearhead→P272

■ 减速机的容许负载惯性惯量 J Permissible Load Inertia J For Gearhead

→272页→P272

■ 外形图（单位 mm）Dimensions(Unit mm)

减速机附有安装用螺丝Mounting screws are included with gearhead.

● 导线型 Lead Wiring Type

重量 Weight：电动机 Motor：0.75kg

减速机 Gearhead：0.4kg

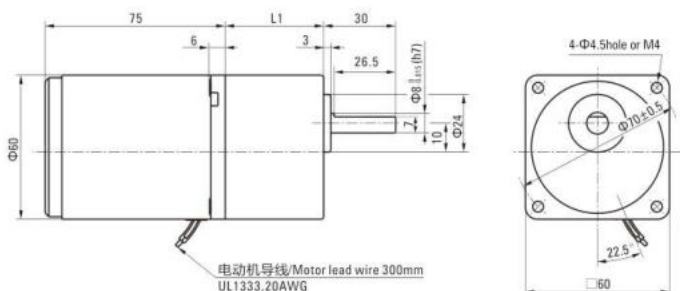

电动机型号 Motor Model	减速器型号 Gearhead Model	减速比 Gear Ratio	L1
2IK6GN-A 2IK6GN-E 2IK6GN-C	2GN□K	3~18	32
2IK6GN-H 2IK6GN-S		25~200	

- 减速器型号的□中为减速比的数值
Enter the gear ratio in the box (□) within the model name

● 圆轴型的转轴部分 Shaft Section Of Round Shaft Type

除重量及轴部外电动机外形与齿轮轴型相同。
Excluding weight and the shaft section motor shape are the same as those of the pinion shaft type.

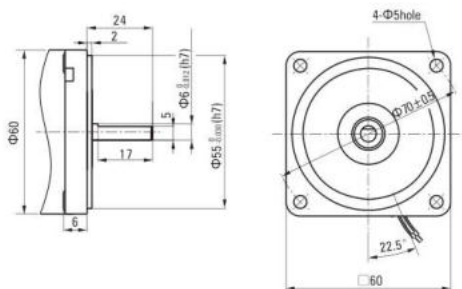

● 中间减速器 Decimal Gearhead

可安装在GN齿轮轴型上 Can be connected to GN pinion shaft type
电动机外形与齿轮轴型相同
2GN10XK
重量 Weight : 0.2kg

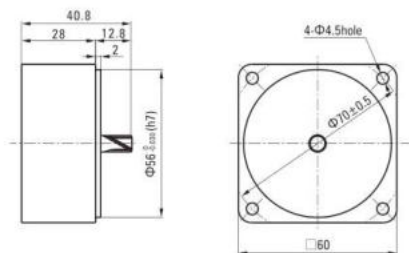

■ 电容器外形尺寸 Formal Dimension Of Capacitor

型号 Model		电容器型号 Capacitor Model	L	W	H
齿轮轴型 Pinion Shaft	圆轴型 Round Shaft				
2IK6GN-A	2IK6A-A	ZD35CFAUL	38	19.5	31
2IK6GN-E	2IK6A-E	ZD20CFAUL	36	15	25
2IK6GN-C	2IK6A-C	ZD08CFAUL	36	10.5	20

● 常规电容器出线为引线,也可根据客户要求配置插片式187#

Note: Conventional capacitor is a lead wire type. Inserted 187# is optional

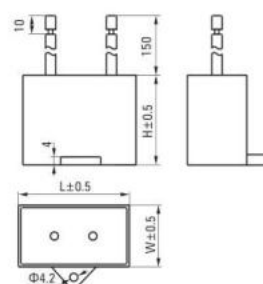

■ 连接图 Wiring Diagram

● 运转方向指从电动机轴看来的方向。CW表示顺时针方向, CCW表示逆时针方向。

The direction of motor rotation is as viewed from the shaft end of motor. CW represents the clockwise direction, while CCW represents the counterclockwise direction.

● 表中所记品名为齿轮轴型, 圆轴型亦同。

Name indicated in the list is pinion shaft type, also valid for the equivalent round shaft type.

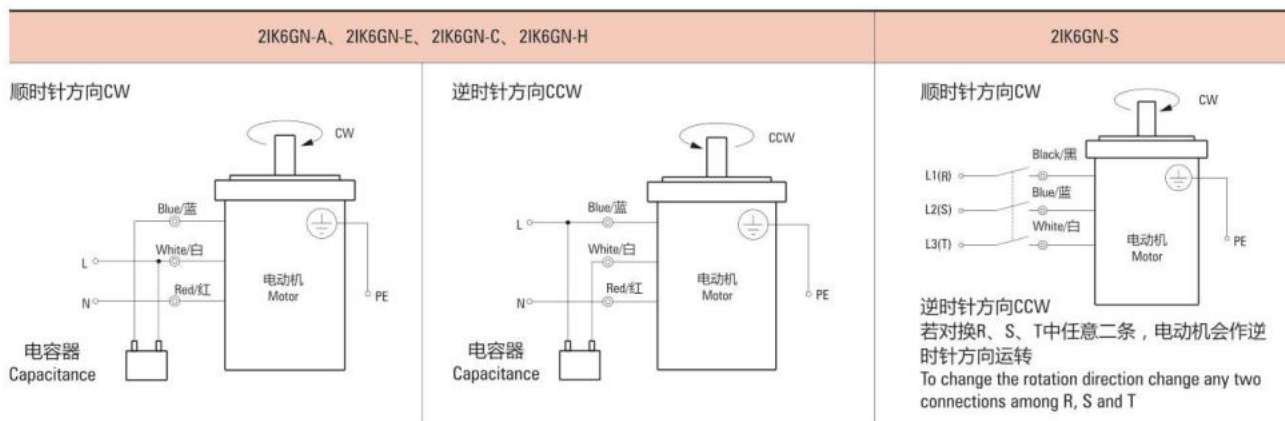

请注意 Note:

单相电动机运转方向的转换应在电动机停止后进行。

Change the direction of single-phase motor rotation only after bring the motor to a stop.

若在电动机运转时转换运转方向, 可能发生无法转换运转方向或须费时较久的情况。

If an attempt is made to change the direction of rotation while the motor is rotating, motor may ignore reversing command or change its direction of rotation after some delay.

感应电动机 INDUCTION MOTORS

■ 15W □ 70mm



规格 Specs 连续额定 Continuous Rating

型号Model · 类型 Type 导线型 Lead Wire Type		输出功率 Output power W	电压 Voltage V	频率 Frequency Hz	电流 Current A	启动转矩 Starting Torque mN.m	额定转矩 Rated Torque mN.m	额定转速 Rated Speed r/min	电容器容量 Capacitor μF
齿轮轴型 Pinion Shaft	圆轴型 Round Shaft								
3IK15GN-A	3IK15A-A	15	1ph 100	50	0.35	90	125	1200	6.0
				60	0.33	85	105	1450	
3IK15GN-E	3IK15A-E	15	1ph 110	60	0.30	65	105	1450	5.0
			1ph 120		0.32				
3IK15GN-C	3IK15A-C	15	1ph 220	50	0.18	90	125	1200	1.2
			1ph 230		0.20				
3IK15GN-H	3IK15A-H	15	1ph 220	60	0.16	65	105	1450	
			1ph 230		0.15				
3IK15GN-S	3IK15A-S	15	3ph 220	50	0.14	220	125	1200	
				60	0.12	180	105	1450	

- 各种安全规格以电动机铭牌上的型号名取得认证。
When the motor is approved under various safety standards, the model name on the nameplate is the approved model name.
- 注：“-A”型号中电压为110V时，配置电容器容量以实际铭牌为准。
Note:“-A” it means the voltage 110V,the assembly capacitor vaule it is according the label.

种类 Type

● 电动机 Motor

机型 Type	型号Model	
	齿轮轴型 Pinion Shaft	圆轴型 Round Shaft
导线型 Lead Wire Type	3IK15GN-A	3IK15A-A
	3IK15GN-E	3IK15A-E
	3IK15GN-C	3IK15A-C
	3IK15GN-H	3IK15A-H
	3IK15GN-S	3IK15A-S

● 平行轴减速器 (另售) Parallel Shaft Gearhead (Sold Separately)

减速器种类 Gearhead Type	减速器型号 Gearhead Model	减速比 Gear Ratio
长寿命●低噪音 Long Life ● Low Noise	3GN□K	3、3.6、5、6、7.5、9、12.5、15、18、25、30、36、50、60、75、90、100、120、150、180、200
	3GN10XK (中间减速器) (Decimal Gearhead)	

- 减速器型号的□中为减速比的数值
Enter the gear ratio in the box (□) within the model name

■ 装有减速器时的容许转矩 Gear Motor-Torque Table

- 减速器另售·中间减速器另售。
Gearhead and mid-gearbox can be sold separately.
- 减速品型号的□中为减速比的数值。
Enter the gear ratio in the box(□) within the model name.
- □色表示与电动机同一方向运转，其他则为相反方向。
The colored background □ indicates the same rotating direction of the motor while the rotating direction of others are opposite.
- 转速是以电动机的同步转速（50Hz：1500r/min、60Hz：1800r/min）为基准除以减速比而算出来的数值。实际转速将随负载大小变化所示数值减少2%~20%左右。
The speed is calculated by dividing the motor's synchronous speed (50Hz：1500r/min、60Hz：1800r/min) by the gear ratio. The actual speed is 2%~20% less than the displayed value, depending on the size of the load.
- 希望以大于下表的减速比进行进一步减速时，可在电动机与减速机之间安装减速比为10的中间减速机。这时的容许转矩为5N·m。
To reduce the speed beyond the gear ratio in the table, attach a decimal gearhead(gear ratio:10)between the gearhead and motor. In that case, the permissible torque is 5 N·m.

■ 容许力矩单位 Allowance Torque Unit：上段 Upside (N.m) /下段 Belowside (kgf.cm)

类型 Type 电动机/减速机 Motor/Gearhead	减速比 Gear Ratio		3	3.6	5	6	7.5	9	12.5	15	18	25	30	36	50	60	75	90	100	120	150	180	200		
	转速 Speed r/min	50Hz	500	417	300	250	200	166	120	100	83	60	50	41	30	25	20	16	15	12.5	10	8.3	7.5		
		60Hz	600	500	360	300	240	200	144	120	100	72	60	50	36	30	24	20	18	15	12	10	9		
3IK15GN-A 3IK15GN-E 3IK15GN-C 3IK15GN-H 3IK15GN-S	3GN□K	50Hz	0.30	0.36	0.51	0.61	0.76	0.91	1.3	1.5	1.8	2.3	2.7	3.3	4.1	5	5	5	5	5	5	5	5	5	
			3.06	3.67	5.20	6.22	7.75	9.28	13.2	15.3	18.3	23.4	27.5	33.7	41.8	50	50	50	50	50	50	50	50	50	
		60Hz	0.26	0.31	0.43	0.51	0.64	0.77	1.1	1.3	1.5	1.9	2.3	2.8	3.5	4.2	5	5	5	5	5	5	5	5	5
			2.65	3.16	4.38	5.20	6.53	7.85	11.2	13.2	15.3	19.3	23.4	28.5	35.7	42.8	50	50	50	50	50	50	50	50	50

■ 容许悬挂负载·容许轴向负载 To Allow The Hoisting Of The Load Allow Axial Load

电动机 (圆轴型) →272页

Motor(Round Shaft) →P272

减速机→272页

Gearhead→P272

■ 减速机的容许负载惯性惯量 J Permissible Load Inertia J For Gearhead

→272页→P272

■ 外形图 (单位 mm) Dimensions(Unit mm)

减速机附有安装用螺丝 Mounting screws are included with gearhead.

● 导线型 Lead Wiring Type

重量 Weight：电动机 Motor：1.1kg

减速机 Gearhead：0.5kg

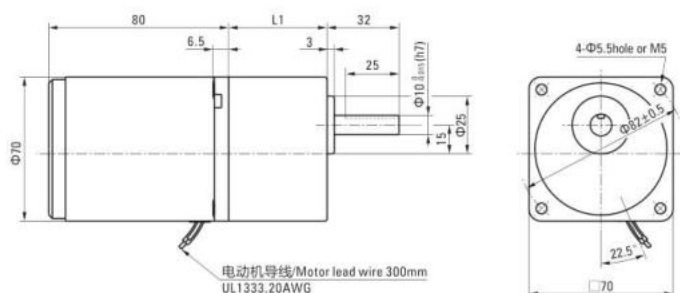

电动机型号 Motor Model	减速器型号 Gearhead Model	减速比 Gear Ratio	L1
3IK15GN-A 3IK15GN-E 3IK15GN-C 3IK15GN-H 3IK15GN-S	3GN□K	3~18	32
		25~200	42

- 减速器型号的□中为减速比的数值
Enter the gear ratio in the box (□) within the model name

● 键·键槽 (减速器附件) Key · Keyway(Accessory Of Gearhead)

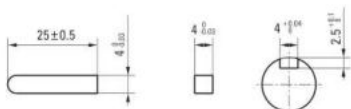

● 圆轴型的转轴部分 Shaft Section Of Round Shaft Type

除重量及轴部外电动机外形与齿轮轴型相同。
Excluding weight and the shaft section motor shape are the same as those of the pinion shaft type.

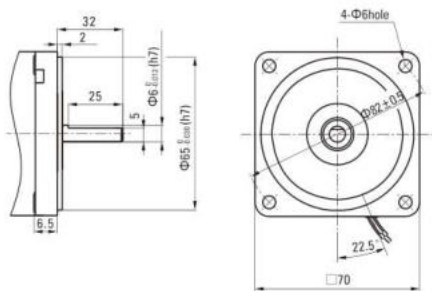

● 中间减速器 Decimal Gearhead

可安装在GN齿轮轴型上 Can be connected to GN pinion shaft type
电动机外形与齿轮轴型相同
3GN10XK
重量 Weight : 0.3kg

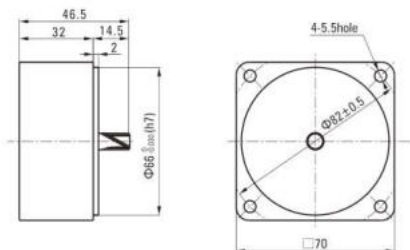

■ 电容器外形尺寸 Formal Dimension Of Capacitor

型号Model		电容器型号 Capacitor Model	L	W	H
齿轮轴型 Pinion Shaft	圆轴型 Round Shaft				
3IK15GN-A	3IK15A-A	ZD60CFAUL	48	23	32
3IK15GN-E	3IK15A-E	ZD50CFAUL	47	20	31
3IK15GN-C	3IK15A-C	ZD12BFAUL	36	12	22

● 常规电容器出线为引线,也可根据客户要求配置插片式187#
Note: Conventional capacitor is a lead wire type. Inserted 187# is optional

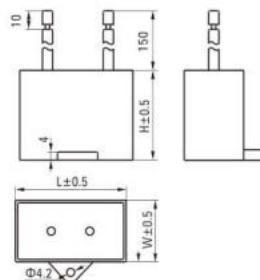

■ 连接图 Wiring Diagram

- 运转方向指从电动机轴看来的方向。CW表示顺时针方向, CCW表示逆时针方向。
The direction of motor rotation is as viewed from the shaft end of motor. CW represents the clockwise direction, while CCW represents the counterclockwise direction.
- 表中所记品名为齿轮轴型, 圆轴型亦同。
Name indicated in the list is pinion shaft type, also valid for the equivalent round shaft type.

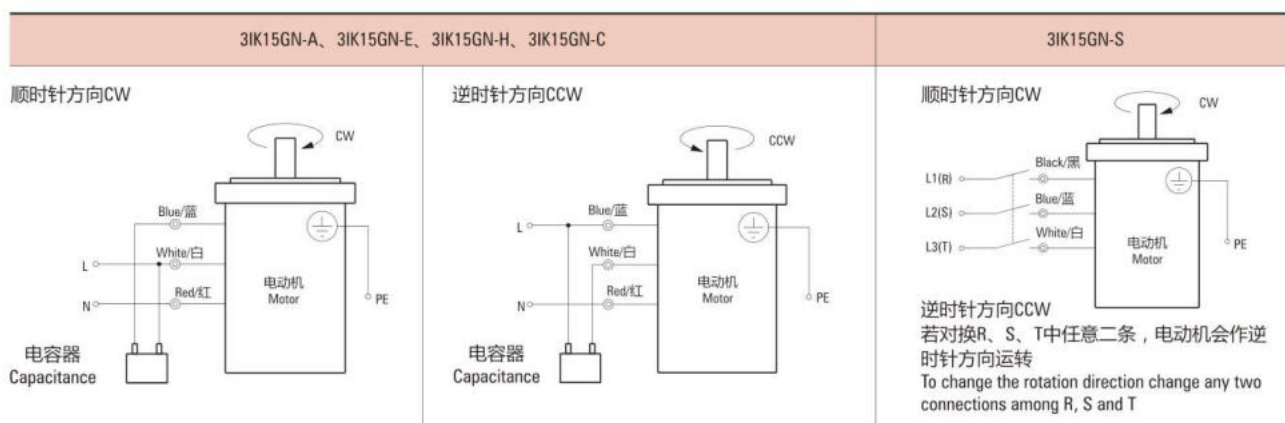

请注意 Note:

单相电动机运转方向的转换应在电动机停止后进行。
Change the direction of single-phase motor rotation only after bring the motor to a stop.
若在电动机运转时转换运转方向,可能发生无法转换运转方向或须费时较久的情况。
If an attempt is made to change the direction of rotation while the motor is rotating, motor may ignore reversing command or change its direction of rotation after some delay.

感应电动机 INDUCTION MOTORS

■ 25W □ 80mm



规格 Specs 连续额定 Continuous Rating

型号 Model · 类型 Type		输出功率 Output power W	电压 Voltage V	频率 Frequency Hz	电流 Current A	启动转矩 Starting Torque mN.m	额定转矩 Rated Torque mN.m	额定转速 Rated Speed r/min	电容器容量 Capacitor μF
上段:齿轮轴 Upper:Pinion Shaft 下段()内:圆轴 Below:Round Shaft	带端子箱型 Terminal Box Type 外形图Dimensions②								
导线型 Lead Wire Type 外形图Dimensions①	带端子箱型 Terminal Box Type 外形图Dimensions②								
4IK25GN-A (4IK25A-A)	4IK25GN-AT (4IK25A-AT)	25	1ph 100	50	0.50	120	200	1250	8.0
				60	0.55		165	1550	
4IK25GN-E (4IK25A-E)	4IK25GN-ET (4IK25A-ET)	25	1ph 110	60	0.45	120	165	1550	7.0
			1ph 120		0.50				
4IK25GN-C (4IK25A-C)	4IK25GN-CT (4IK25A-CT)	25	1ph 220	50	0.25	120	200	1250	1.8
			1ph 230		0.23				
4IK25GN-H (4IK25A-H)	4IK25GN-HT (4IK25A-HT)	25	1ph 220	60	0.23	120	165	1550	
			1ph 230						
4IK25GN-S (4IK25A-S)	4IK25GN-ST (4IK25A-ST)	25	3ph 220	50	0.185	350	200	1250	
				60	0.170				

●各种安全规格以电动机铭牌上的型号名取得认证。

When the motor is approved under various safety standards, the model name on the nameplate is the approved model name.

●注：“-A”型号中电压为110V时，配置电容器容量以实际铭牌为准。

Note:“-A” it means the voltage 110v,the assembly capacitor vaule it is according the labe.

种类 Type

● 电动机 Motor

机型 Type	型号 Model	
	齿轮轴型 Pinion Shaft	圆轴型 Round Shaft
导线型 Lead Wire Type	4IK25GN-A	4IK25A-A
	4IK25GN-E	4IK25A-E
	4IK25GN-C	4IK25A-C
	4IK25GN-H	4IK25A-H
	4IK25GN-S	4IK25A-S
带端子箱型 Terminal Box Type	4IK25GN-AT	4IK25A-AT
	4IK25GN-ET	4IK25A-ET
	4IK25GN-CT	4IK25A-CT
	4IK25GN-HT	4IK25A-HT
	4IK25GN-ST	4IK25A-ST

● 平行轴减速器（另售） Parallel Shaft Gearhead (Sold Separately)

减速器种类 Gearhead Type	减速器型号 Gearhead Model	减速比 Gear Ratio
长寿命●低噪音 Long Life ● Low Noise	4GN□K	3、3.6、5、6、7.5、9、12.5、15、18、25、30、36、50、60、75、90、100、120、150、180、200
	4GN10XK (中间减速器 Decimal Gearhead)	

●减速器型号的□中为减速比的数值

Enter the gear ratio in the box (□) within the model name

■ 装有减速器时的容许转矩 Gear Motor-Torque Table

- 减速器另售·中间减速器另售。电动机型号的□中为表示带端子箱型的记号(T)。
Gearhead and mid-gearbox can be sold separately. Enter the code that represents the terminal box type (T) in the box (□) within the model name.
- 减速品型号的□中为减速比的数值。
Enter the gear ratio in the box(□) within the model name.
- □色表示与电动机同一方向运转，其他则为相反方向。
The colored background □ indicates the same rotating direction of the motor while the rotating direction of others are opposite.
- 转速是以电动机的同步转速 (50Hz : 1500r/min、60Hz : 1800r/min) 为基准除以减速比而算出来的数值。实际转速将随负载大小变化所示数值减少2%~20%左右。
The speed is calculated by dividing the motor's synchronous speed(50Hz : 1500r/min、60Hz : 1800r/min) by the gear ratio. The actual speed is 2%~20% less than the displayed value, depending on the size of the load.
- 希望以大于下表的减速比进行进一步减速时，可在电动机与减速机之间安装减速比为10的中间减速机。这时的容许转矩为8N·m。
To reduce the speed beyond the gear ratio in the table, attach a decimal gearhead(gear ratio:10)between the gearhead and motor. In that case, the permissible torque is 8 N·m.

■ 容许力矩单位 Allowance Torque Unit : 上段 Upside (N.m) /下段 Belowside (kgf.cm)

类型 Type 电动机/减速机 Motor/Gearhead	减速比 Gear Ratio		3	3.6	5	6	7.5	9	12.5	15	18	25	30	36	50	60	75	90	100	120	150	180	200
	转速 Speed r/min	50Hz	500	417	300	250	200	166	120	100	83	60	50	41	30	25	20	16	15	12.5	10	8.3	7.5
4K25GN-A□ 4K25GN-E□ 4K25GN-C□ 4K25GN-H□ 4K25GN-S□	4GN□K	50Hz	0.49	0.58	0.81	0.97	1.2	1.5	2.0	2.4	2.9	3.7	4.4	5.3	6.6	7.9	8	8	8	8	8	8	8
		60Hz	5.00	5.91	8.26	9.89	12.2	15.3	20.4	24.4	29.6	37.7	44.9	54.1	67.3	80	80	80	80	80	80	80	80
	4GN□K	50Hz	0.40	0.48	0.67	0.80	1.0	1.2	1.7	2.0	2.4	3.0	3.6	4.3	5.4	6.5	8	8	8	8	8	8	8
		60Hz	4.08	4.89	6.83	8.16	10.2	12.2	17.3	20.4	24.4	30.6	36.7	43.8	55.1	66.3	80	80	80	80	80	80	80

■ 容许悬挂负载 · 容许轴向负载 To Allow The Hoisting Of The Load Allow Axial Load

电动机 (圆轴型) → 272页 Motor(Round Shaft) → P272
 减速机 → 272页 Gearhead → P272

■ 减速机的容许负载惯性惯量 J Permissible Load Inertia J For Gearhead

→ 272页 → P272

■ 外形图 (单位 mm) Dimensions(Unit mm)

减速器附有安装用螺丝 Mounting screws are included with gearhead.

● 导线型 Lead Wiring Type ①

重量 Weight : 电动机 Motor : 1.6kg 减速机 Gearhead : 0.80kg

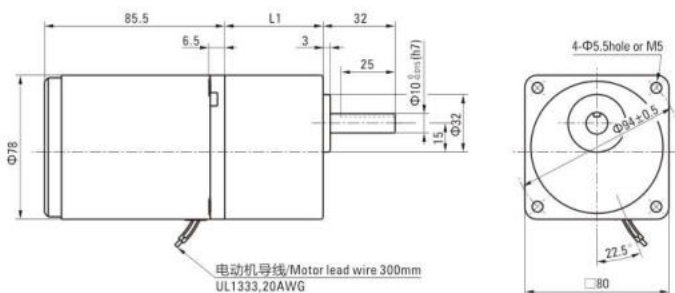

电动机型号 Motor Model	减速器型号 Gearhead Model	减速比 Gear Ratio	L1
4K25GN-A	4GN□K	3~18	32
4K25GN-E		25~200	43.5
4K25GN-C			
4K25GN-H			
4K25GN-S			

- 减速器型号的□中为减速比的数值
Enter the gear ratio in the box (□) within the model name

带端子箱型 Terminal Box Type ②

重量 Weight : 电动机 Motor : 1.75kg

减速器 Gearhead : 0.8kg

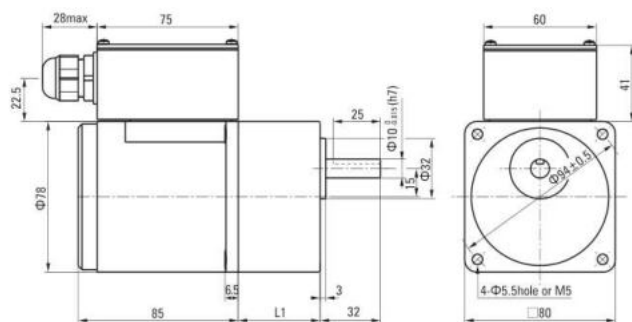

电动机型号 Motor Model	减速器型号 Gearhead Model	减速比 Gear Ratio	L1
4IK25GN-AT	4GN□K	3~18	32
4IK25GN-ET			
4IK25GN-CT		25~200	43.5
4IK25GN-HT			
4IK25GN-ST			

●减速器型号的□中为减速比的数值

Enter the gear ratio in the box (□) within the model name

键·键槽 (减速器附件) Key·Keyway(Accessory Of Gearhead)

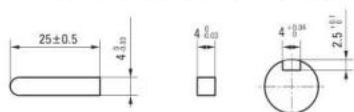

圆轴型的转轴部分 Shaft Section Of Round Shaft Type

除重量及轴部外电动机外形与齿轮轴型相同。

Excluding weight and the shaft section motor shape are the same as those of the pinion shaft type.

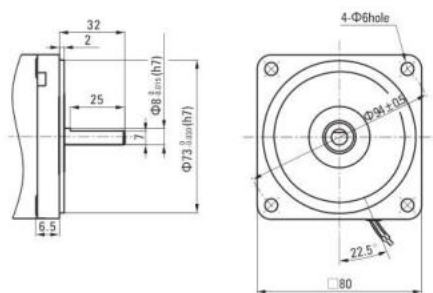

中间减速器 Decimal Gearhead

可安装在GN齿轮轴型上 Can be connected to GN pinion shaft type

电动机外形与齿轮轴型相同

4GN10XK

重量 Weight : 0.41kg

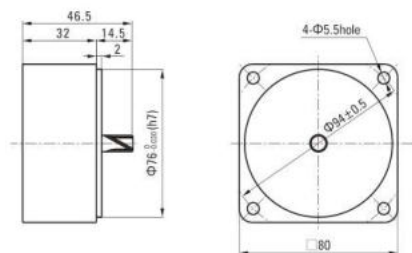

电容器外形尺寸 Formal Dimension Of Capacitor

型号 Model		电容器型号 Capacitor Model	L	W	H
齿轮轴型 Pinion Shaft	圆轴型 Round Shaft				
4IK25GN-A□	4IK25A-A□	ZD80CFAUL	48	26.5	38
4IK25GN-E□	4IK25A-E□	ZD70CFAUL	47	24	37
4IK25GN-C□	4IK25A-C□	ZD18BFAUL	36	13.5	24

●常规电容器出线为引线,也可根据客户要求配置插片式187#

Note: Conventional capacitor is a lead wire type. Inserted 187# is optional

●电动机型号的□中为表示带端子箱型的记号(T)

Enter the code that represents the terminal box type "T" in the box (□) within the model name

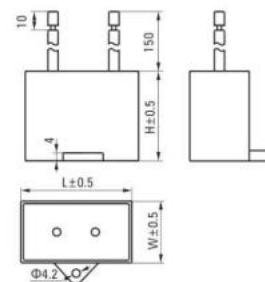

弧锥直角 SPIRAL BEVEL RIGHT ANGLE

■ 装有减速器时的容许转矩 Gear Motor-Torque Table

- 减速器-中间减速器另售。• 电动机型号的□中为表示带端子箱型的记号(T)。
Gearhead and mid-gearbox can be sold separately. Enter the code that represents the terminal box type (T) in the box (□) within the model name.
- 减速器型号的□中为减速比的数值。□色表示与电动机同一方向运转，其他则为相反方向。
Enter the gear ratio in the box (□) within the model name.
The colored background □ indicates the same rotating direction of the motor while the rotating direction of others are opposite.
- 转速是以电动机的同步转速 (50Hz:1500r/min、60Hz:1800r/min) 为基准除以减速比而算出来的数值。实际转速将随负载大小变化而比所示数值减少2%~20%左右。
The speed is calculated by dividing the motor's synchronous speed (50Hz:1500r/min、60Hz:1800r/min) by the gear ratio. The actual speed is 2%~20% less than the displayed value, depending on the size of the load.
- 希望以大于下表的减速比进行进一步减速时，可在电动机与减速器之间安装减速比为10的中间减速器。这时的容许转矩为8N·m。
To reduce the speed beyond the gear ratio in the table, attach a mid-gearbox (gear ratio:10) between the gearhead and motor. In that case, the permissible torque is 8N·m.

■ 容许力矩单位 Allowance Torque Unit: 上段 Upside (N.m) / 下段 Belowside (kgf.cm)

机型Type	减速比Gear Ratio	3	3.6	5	6	7.5	9	12.5	15	18	25	30	36	50	60	75	90	100	120	150	180		
电动机/减速器 Motor/Gearhead	转速Speed r/min	50Hz	500	417	300	250	200	166	120	100	83	60	50	42	30	25	20	16	15	12	10	8	
	60Hz	600	500	360	300	240	200	144	120	100	72	60	50	36	30	24	20	18	15	12	10		
4IK25GN-A□ 4IK25GN-E□ 4IK25GN-C□ 4IK25GN-H□ 4IK25GN-S□	容许力矩 Allowance Torque	50Hz	4GN□RC	0.36	0.43	0.59	0.71	0.99	1.18	1.64	1.97	2.37	3.29	3.95	4.73	6.58	7.10	8.00	8.00	8.00	8.00	8.00	8.00
			4GN□RT	3.62	4.35	6.04	7.25	10.1	12.1	16.8	20.1	24.2	33.5	40.3	48.3	67.1	72.5	80.0	80.00	80.00	80.00	80.00	80.00
		60Hz	4GN□RC	0.29	0.34	0.48	0.57	0.80	0.95	1.33	1.59	1.91	2.65	3.18	3.82	5.30	5.73	7.16	8.00	8.00	8.00	8.00	8.00
			4GN□RT	2.92	3.51	4.87	5.84	8.12	9.74	13.5	16.2	19.5	27.1	32.5	39.0	54.1	58.4	73.0	80.00	80.00	80.00	80.00	80.00

■ 感应尺寸图 Induction Type Drawing

4IK25GN-A□/4GN□RC 4IK25GN-E□/4GN□RC	4IK25GN-C□/4GN□RC 4IK25GN-H□/4GN□RC	4IK25GN-S□/4GN□RC	4IK25GN-A□/4GN□RT 4IK25GN-E□/4GN□RT	4IK25GN-C□/4GN□RT 4IK25GN-H□/4GN□RT	4IK25GN-S□/4GN□RT
--	--	-------------------	--	--	-------------------

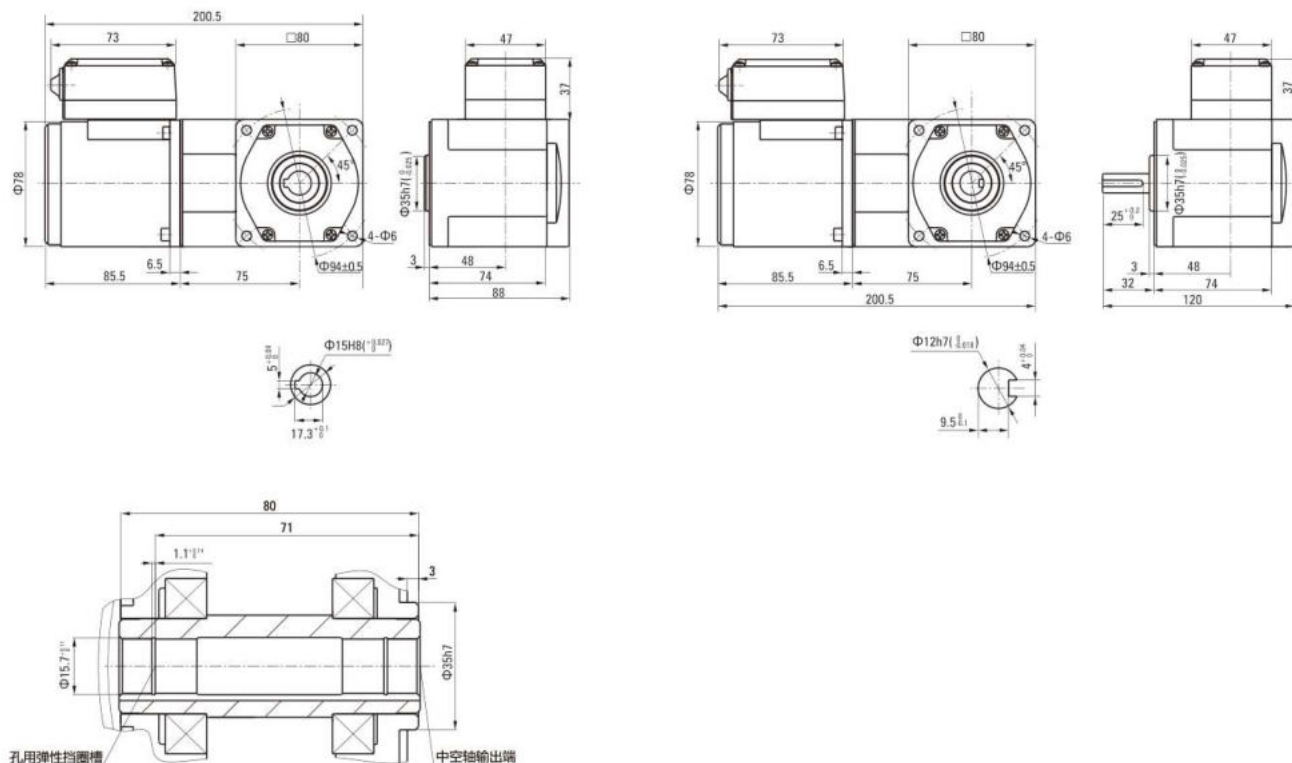

蜗轮蜗杆直角 WORM GEAR RIGHT ANGLE

■ 装有减速器时的容许转矩 Gear Motor-Torque Table

- 减速器-中间减速器另售。• 电动机型号的□中为表示带端子箱型的记号(T)。
Gearhead and mid-gearbox can be sold separately. Enter the code that represents the terminal box type (T) in the box (□) within the model name.
- 减速器型号的□中为减速比的数值。□色表示与电动机同一方向运转，其他则为相反方向。
Enter the gear ratio in the box (□) within the model name.
The colored background □ indicates the same rotating direction of the motor while the rotating direction of others are opposite.
- 转速是以电动机的同步转速 (50Hz:1500r/min、60Hz:1800r/min) 为基准除以减速比而算出来的数值。实际转速将随负载大小变化而比所示数值减少2%~20%左右。
The speed is calculated by dividing the motor's synchronous speed (50Hz:1500r/min、60Hz:1800r/min) by the gear ratio. The actual speed is 2%~20% less than the displayed value, depending on the size of the load.
- 希望以大于下表的减速比进行进一步减速时，可在电动机与减速器之间安装减速比为10的中间减速器。这时的容许转矩为8N·m。
To reduce the speed beyond the gear ratio in the table, attach a mid-gearbox (gear ratio:10) between the gearhead and motor. In that case, the permissible torque is 8N·m.

■ 容许力矩单位 Allowance Torque Unit: 上段 Upside (N.m) / 下段 Belowside (kgf.cm)

机型Type	减速比Gear Ratio	3	3.6	5	6	7.5	9	12.5	15	18	25	30	36	50	60	75	90	100	120	150	180		
电动机/减速器 Motor/Gearhead	转速Speed r/min	50Hz	500	417	300	250	200	166	120	100	83	60	50	42	30	25	20	16	15	12	10	8	
	60Hz	600	500	360	300	240	200	144	120	100	72	60	50	36	30	24	20	18	15	12	10		
4IK25GN-A□ 4IK25GN-E□ 4IK25GN-C□ 4IK25GN-H□ 4IK25GN-S□	容许力矩 Allowance Torque	50Hz	4GN□RH	0.26	0.31	0.39	0.46	0.58	0.70	0.97	1.16	1.39	1.93	2.32	2.78	3.87	4.64	5.80	6.96	7.74	8.00	8.00	8.00
			4GN□RA	2.63	3.16	3.95	4.74	5.92	7.10	9.87	11.8	14.2	19.7	23.7	28.4	39.5	47.4	59.2	71.0	78.9	80.0	80.0	80.0
		60Hz	4GN□RH	0.21	0.31	0.39	0.46	0.58	0.70	0.97	1.16	1.39	1.93	2.32	2.78	3.87	4.64	5.82	6.96	7.74	8.00	8.00	8.00
			4GN□RA	2.12	3.16	3.95	4.74	5.92	7.10	9.87	11.8	14.2	19.7	23.7	28.4	39.5	47.4	59.2	71.0	78.9	80.0	80.0	8.00

■ 感应尺寸图 Induction Type Drawing

4IK25GN-A□/4GN□RH 4IK25GN-E□/4GN□RH	4IK25GN-C□/4GN□RH 4IK25GN-H□/4GN□RH	4IK25GN-S□/4GN□RH	4IK25GN-A□/4GN□RA 4IK25GN-E□/4GN□RA	4IK25GN-C□/4GN□RA 4IK25GN-H□/4GN□RA	4IK25GN-S□/4GN□RA
--	--	-------------------	--	--	-------------------

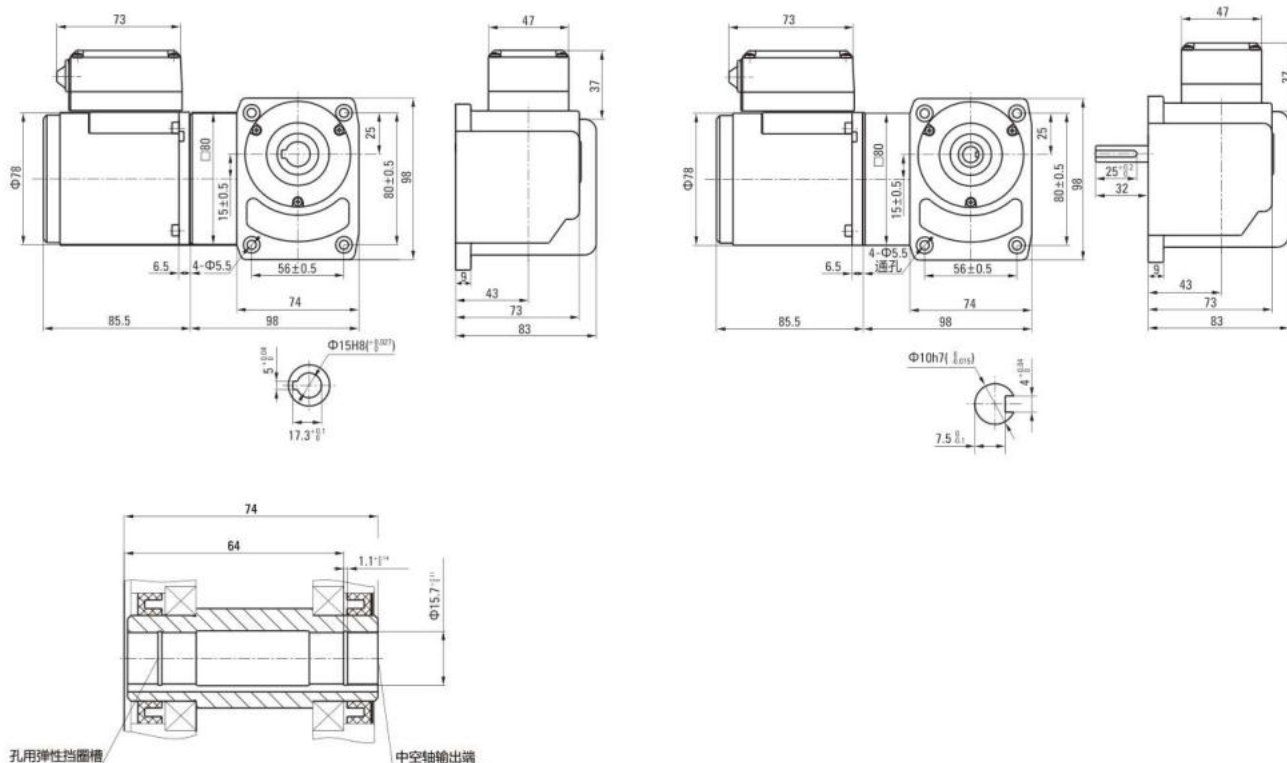

连接图 Wiring Diagram

● 运转方向指从电动机轴看来的方向。CW表示顺时针方向，CCW表示逆时针方向。

The direction of motor rotation is as viewed from the shaft end of motor. CW represents the clockwise direction, while CCW represents the counterclockwise direction.

● 表中所记品名为齿轮轴型，圆轴型亦同。

Name indicated in the list is pinion shaft type, also valid for the equivalent round shaft type.

导线型 Lead Wire Type		
4IK25GN-A、4IK25GN-E、4IK25GN-H、4IK25GN-C		4IK25GN-S
<p>顺时针方向CW</p> <p>电容器 Capacitance</p>	<p>逆时针方向CCW</p> <p>电容器 Capacitance</p>	<p>顺时针方向CW</p> <p>电动机 Motor</p> <p>逆时针方向CCW 若对换R、S、T中任意二条，电动机会作逆时针方向运转 To change the rotation direction change any two connections among R, S and T</p>
带端子箱型 Terminal Box Type		
4IK25GN-AT、4IK25GN-ET、4IK25GN-HT、4IK25GN-CT		4IK25GN-ST
<p>顺时针方向CW</p> <p>电动机 Motor</p> <p>电容器 Capacitance</p>	<p>逆时针方向CCW</p> <p>电动机 Motor</p> <p>电容器 Capacitance</p>	<p>顺时针方向CW</p> <p>电动机 Motor</p> <p>逆时针方向CCW 若对换U、V、W中任意二条，电动机会作逆时针方向运转 To change the rotation direction change any two connections among U, V and W</p>

请注意 Note:

单相电动机运转方向的转换应在电动机停止后进行。

Change the direction of single-phase motor rotation only after bring the motor to a stop.

若在电动机运转时转换运转方向，可能发生无法转换运转方向或须费时较久的情况。

If an attempt is made to change the direction of rotation while the motor is rotating, motor may ignore reversing command or change its direction of rotation after some delay.

感应电动机 INDUCTION MOTORS

■ 40W □ 90mm



规格 Specs 连续额定 Continuous Rating

型号 Model · 类型 Type		输出功率 Output power W	电压 Voltage V	频率 Frequency Hz	电流 Current A	启动转矩 Starting Torque mN.m	额定转矩 Rated Torque mN.m	额定转速 Rated Speed r/min	电容器容量 Capacitor μF
上段:齿轮轴 Upper:Pinion Shaft 下段()内:圆轴 Below:Round Shaft	带端子箱型 Terminal Box Type 外形图Dimensions②								
导线型 Lead Wire Type 外形图Dimensions①	带端子箱型 Terminal Box Type 外形图Dimensions②								
5IK40GN-A (5IK40A-A)	5IK40GN-AT (5IK40A-AT)	40	1ph 100	50	0.65	220	315	1250	12.0
				60	0.70		260	1550	
5IK40GN-E (5IK40A-E)	5IK40GN-ET (5IK40A-ET)	40	1ph 110	60	0.55	200	260	1550	8.0
			1ph 120		0.60				
5IK40GN-C (5IK40A-C)	5IK40GN-CT (5IK40A-CT)	40	1ph 220	50	0.35	220	315	1250	2.5
			1ph 230		0.40				
5IK40GN-H (5IK40A-H)	5IK40GN-HT (5IK40A-HT)	40	1ph 220	60	0.35	200	260	1550	
			1ph 230		0.40				
5IK40GN-S (5IK40A-S)	5IK40GN-ST (5IK40A-ST)	40	3ph 220	50	0.30	800	315	1250	
				60	0.25				

●各种安全规格以电动机铭牌上的型号名取得认证。

When the motor is approved under various safety standards, the model name on the nameplate is the approved model name.

●注：90-40W直角减速电机均为(GU)加强型。 Note:90-40W right angle gear motor all motor is (GU)strength type.

●注：“-A”型号中电压为110V时，配置电容器容量以实际铭牌为准。 Note：“-A” it means the voltage 110v,the assembly capacitor vaule it is according the labe.

种类 Type

●电动机 Motor

机型 Type	型号 Model	
	齿轮轴型 Pinion Shaft	圆轴型 Round Shaft
导线型 Lead Wire Type	5IK40GN-A	5IK40A-A
	5IK40GN-E	5IK40A-E
	5IK40GN-C	5IK40A-C
	5IK40GN-H	5IK40A-H
	5IK40GN-S	5IK40A-S
带端子箱型 Terminal Box Type	5IK40GN-AT	5IK40A-AT
	5IK40GN-ET	5IK40A-ET
	5IK40GN-CT	5IK40A-CT
	5IK40GN-HT	5IK40A-HT
	5IK40GN-ST	5IK40A-ST

●平行轴减速器(另售) Parallel Shaft Gearhead (Sold Separately)

减速器种类 Gearhead Type	减速器型号 Gearhead Model	减速比 Gear Ratio
长寿命●低噪音 Long Life ● Low Noise	5GN□K	3、3.6、5、6、7.5、9、12.5、15、18、25、30、36、50、60、75、90、100、120、150、180、200
	5GN10XK (中间减速器 Decimal Gearhead)	

●减速器型号的□中为减速比的数值

Enter the gear ratio in the box (□) within the model name

■ 装有减速器时的容许转矩 Gear Motor-Torque Table

- 减速器另售·中间减速器另售。电动机型号的□中为表示带端子箱型的记号(T)。
Gearhead and mid-gearbox can be sold separately. Enter the code that represents the terminal box type (T) in the box (□) within the model name.
- 减速品型号的□中为减速比的数值。
Enter the gear ratio in the box(□) within the model name.
- □色表示与电动机同一方向运转，其他则为相反方向。
The colored background □ indicates the same rotating direction of the motor while the rotating direction of others are opposite.
- 转速是以电动机的同步转速 (50Hz : 1500r/min、60Hz : 1800r/min) 为基准除以减速比而算出来的数值。实际转速将随负载大小变化所示数值减少2%~20%左右。
The speed is calculated by dividing the motor's synchronous speed(50Hz : 1500r/min、60Hz : 1800r/min) by the gear ratio. The actual speed is 2%~20% less than the displayed value, depending on the size of the load.
- 希望以大于下表的减速比进行进一步减速时，可在电动机与减速机之间安装减速比为10的中间减速机。这时的容许转矩为10N·m。
To reduce the speed beyond the gear ratio in the table, attach a decimal gearhead(gear ratio:10)between the gearhead and motor. In that case, the permissible torque is 10N·m.

■ 容许力矩单位 Allowance Torque Unit : 上段 Upside (N.m) /下段 Belowside (kgf.cm)

类型 Type 电动机/减速机 Motor/Gearhead	减速比 Gear Ratio	转速 Speed r/min	3	3.6	5	6	7.5	9	12.5	15	18	25	30	36	50	60	75	90	100	120	150	180	200	
			50Hz	60Hz	50Hz	60Hz	50Hz	60Hz	50Hz	60Hz	50Hz	60Hz	50Hz	60Hz	50Hz	60Hz	50Hz	60Hz	50Hz	60Hz	50Hz	60Hz	50Hz	60Hz
5IK40GN-A□ 5IK40GN-E□ 5IK40GN-C□ 5IK40GN-H□ 5IK40GN-S□	5GN□K	50Hz	0.77	0.92	1.3	1.5	1.9	2.3	3.2	3.8	4.6	5.7	6.9	8.3	10	10	10	10	10	10	10	10	10	
			7.85	9.38	13.2	15.3	19.4	23.4	32.6	38.7	46.9	58.1	70.4	84.7	100	100	100	100	100	100	100	100	100	
		60Hz	0.63	0.76	1.1	1.3	1.6	1.9	2.6	3.2	3.8	4.7	5.7	6.8	8.6	10	10	10	10	10	10	10	10	10
			6.42	7.75	11.2	13.2	16.3	19.3	26.5	32.6	38.7	47.9	58.1	69.3	87.7	100	100	100	100	100	100	100	100	100

■ 容许悬挂负载 · 容许轴向负载 To Allow The Hoisting Of The Load Allow Axial Load

电动机 (圆轴型) →P272 Motor(Round Shaft) →P272
减速机 →P272 Gearhead →P272

■ 减速机的容许负载惯性惯量 J Permissible Load Inertia J For Gearhead

→P272 →P272

■ 外形图 (单位 mm) Dimensions(Unit mm)

减速器附有安装用螺丝 Mounting screws are included with gearhead.

● 导线型 Lead Wiring Type ①

重量 Weight : 电动机 Motor : 2.4kg 减速器 Gearhead : 1.35kg

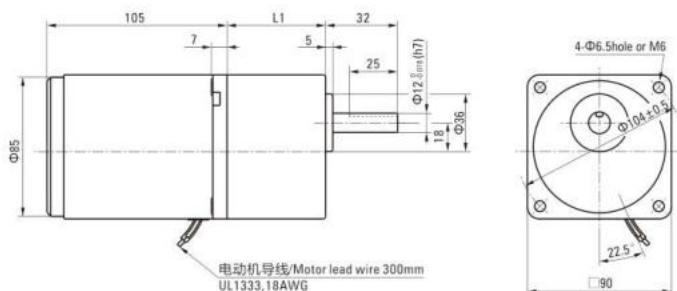

电动机型号 Motor Model	减速器型号 Gearhead Model	减速比 Gear Ratio	L1
5IK40GN-A	5GN□K	3~18	42
5IK40GN-E			
5IK40GN-C			
5IK40GN-H	25~200	60	60
5IK40GN-S			

- 减速器型号的□中为减速比的数值
Enter the gear ratio in the box (□) within the model name

带端子箱型 Terminal Box Type ②

重量 Weight : 电动机 Motor : 2.55kg

减速器 Gearhead : 1.35kg

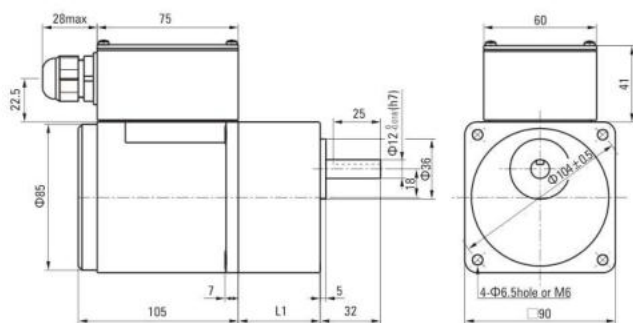

电动机型号 Motor Model	减速器型号 Gearhead Model	减速比 Gear Ratio	L1
5IK40GN-AT	5GN□K	3~18	42
5IK40GN-ET			
5IK40GN-CT		25~200	60
5IK40GN-HT			
5IK40GN-ST			

●减速器型号的□中为减速比的数值

Enter the gear ratio in the box (□) within the model name

键·键槽 (减速器附件) Key · Keyway(Accessory Of Gearhead)

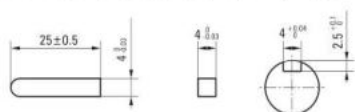

圆轴型的转轴部分 Shaft Section Of Round Shaft Type

除重量及轴部外电动机外形与齿轮轴型相同。

Excluding weight and the shaft section motor shape are the same as those of the pinion shaft type.

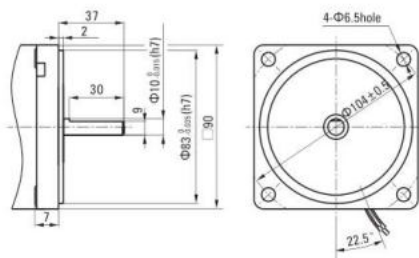

中间减速器 Decimal Gearhead

可安装在GN齿轮轴型上 Can be connected to GN pinion shaft type

电动机外形与齿轮轴型相同

5GN10XK

重量 Weight : 0.6kg

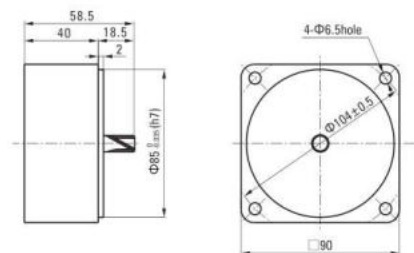

电容器外形尺寸 Formal Dimension Of Capacitor

型号 Model		电容器型号 Capacitor Model	L	W	H
齿轮轴型 Pinion Shaft	圆轴型 Round Shaft				
5IK40GN-A□	5IK40A-A□	ZD120CFAUL	47	17	31
5IK40GN-E□	5IK40A-E□	ZD80CFAUL	48	26.5	38
5IK40GN-C□	5IK40A-C□	ZD25BFAUL	38	17	28

●常规电容器出线为引线,也可根据客户要求配置插片式187#

Note: Conventional capacitor is a lead wire type. Inserted 187# is optional

●电动机型号的□中为表示带端子箱型的记号(T)

Enter the code that represents the terminal box type (T) in the box (□) within the model name

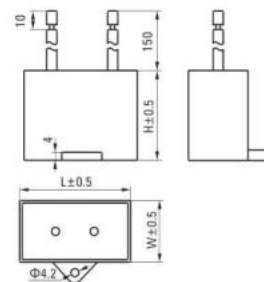

弧锥直角 SPIRAL BEVEL RIGHT ANGLE

■ 装有减速器时的容许转矩 Gear Motor-Torque Table

- 减速器 中间减速器另售。 • 电动机型号的□中为表示带端子箱型的记号(T)。
Gearhead and mid-gearbox can be sold separately. Enter the code that represents the terminal box type (T) in the box (□) within the model name.
- 减速器型号的□中为减速比的数值。 □ 色表示与电动机同一方向运转，其他则为相反方向。
Enter the gear ratio in the box (□) within the model name.
The colored background □ indicates the same rotating direction of the motor while the rotating direction of others are opposite.
- 转速是以电动机的同步转速 (50Hz:1500r/min、60Hz:1800r/min) 为基准除以减速比而算出来的数值。实际转速将随负载大小变化而比所示数值减少2%~20%左右。
The speed is calculated by diving the motor's synchronous speed (50Hz:1500r/min、60Hz:1800r/min) by the gear ratio. The actual speed is 2%~20% less than the displayed value, depending on the size of the load.
- 希望以大于下表的减速比进行进一步减速时，可在电动机与减速器之间安装减速比为10的中间减速器。这时的容许转矩为20N·m。
To reduce the speed beyond the gear ratio in the table, attach a mid-gearbox (gear ratio:10) between the gearhead and motor. In that case, the permissible torque is 20N·m.

■ 容许力矩单位 Allowance Torque Unit: 上段 Upside (N.m) / 下段 Belowside (kgf.cm)

机型Type 电动机/减速器 Motor/Gearhead	减速比Gear Ratio	容许力矩 Allowance Torque																				
		3	3.6	5	6	7.5	9	12.5	15	18	25	30	36	50	60	75	90	100	120	150	180	
5IK40GU-A□ 5IK40GU-E□ 5IK40GU-C□ 5IK40GU-H□ 5IK40GU-S□	5GU□RC 5GU□RT	50Hz	500	417	300	250	200	166	120	100	83	60	50	42	30	25	20	16	15	12	10	8
		60Hz	600	500	360	300	240	200	144	120	100	72	60	50	36	30	24	20	18	15	12	10
5IK40GU-A□ 5IK40GU-E□ 5IK40GU-C□ 5IK40GU-H□ 5IK40GU-S□	5GU□RC 5GU□RT	50Hz	0.57	0.68	0.59	1.14	1.58	1.89	2.63	3.16	3.79	5.26	6.31	6.8	9.5	11.4	14.2	17.0	18.9	20.0	20.0	20.0
		60Hz	0.46	0.55	0.76	0.92	1.27	1.53	2.12	2.55	3.05	4.24	5.09	5.50	7.64	9.16	11.5	13.7	15.3	18.3	20.0	20.0
5IK40GU-A□ 5IK40GU-E□ 5IK40GU-C□ 5IK40GU-H□ 5IK40GU-S□	5GU□RC 5GU□RT	50Hz	5.80	6.96	9.66	11.6	16.1	19.3	26.8	32.2	38.6	53.7	64.4	70	97	116	145	174	193	200	200	200
		60Hz	4.67	5.61	7.79	9.35	13.0	15.6	21.6	26.0	31.2	43.3	51.9	56.1	77.9	93.5	117	140	156	187	200	200

■ 感应尺寸图 Induction Type Drawing

5IK40GU-A□/5GU□RC 5IK40GU-E□/5GU□RC	5IK40GU-C□/5GU□RC 5IK40GU-H□/5GU□RC	5IK40GU-S□/5GU□RC	5IK40GU-A□/5GU□RT 5IK40GU-E□/5GU□RT	5IK40GU-C□/5GU□RT 5IK40GU-H□/5GU□RT	5IK40GU-S□/5GU□RT
--	--	-------------------	--	--	-------------------

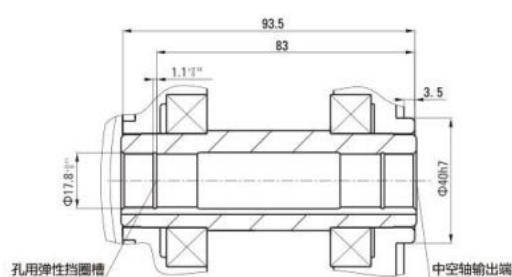
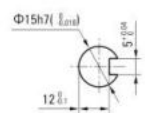
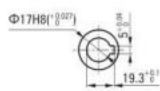
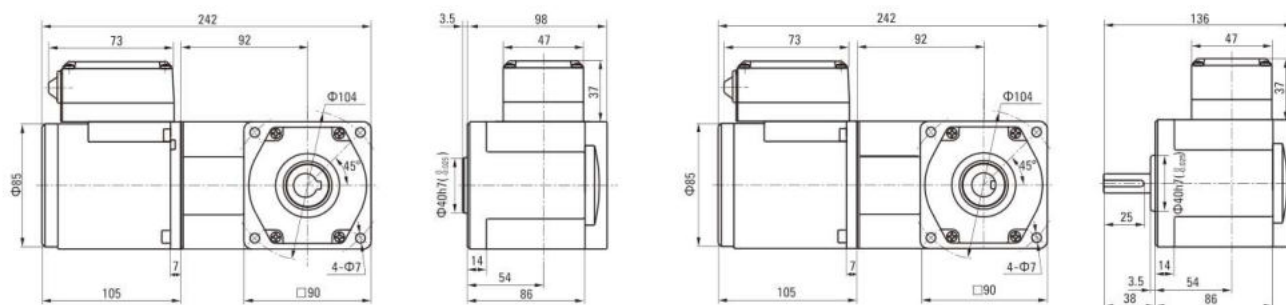

连接图 Wiring Diagram

●运转方向指从电动机轴看来的方向。CW表示顺时针方向，CCW表示逆时针方向。

The direction of motor rotation is as viewed from the shaft end of motor. CW represents the clockwise direction, while CCW represents the counterclockwise direction.

●表中所记品名为齿轮轴型，圆轴型亦同。

Name indicated in the list is pinion shaft type, also valid for the equivalent round shaft type.

导线型 Lead Wire Type		
5IK40GN-A、5IK40GN-E、5IK40GN-H、5IK40GN-C		5IK40GN-S
<p>顺时针方向CW</p> <p>电容器 Capacitance</p>	<p>逆时针方向CCW</p> <p>电容器 Capacitance</p>	<p>顺时针方向CW</p> <p>逆时针方向CCW 若对换R、S、T中任意二条，电动机会作逆时针方向运转 To change the rotation direction change any two connections among R, S and T</p>
带端子箱型 Terminal Box Type		
5IK40GN-AT、5IK40GN-ET、5IK40GN-HT、5IK40GN-CT		5IK40GN-ST
<p>顺时针方向CW</p> <p>电容器 Capacitance</p>	<p>逆时针方向CCW</p> <p>电容器 Capacitance</p>	<p>顺时针方向CW</p> <p>逆时针方向CCW 若对换U、V、W中任意二条，电动机会作逆时针方向运转 To change the rotation direction change any two connections among U, V and W</p>

请注意 Note:

单相电动机运转方向的转换应在电动机停止后进行。

Change the direction of single-phase motor rotation only after bring the motor to a stop.

若在电动机运转时转换运转方向，可能发生无法转换运转方向或须费时较久的情况。

If an attempt is made to change the direction of rotation while the motor is rotating, motor may ignore reversing command or change its direction of rotation after some delay.

感应电动机 INDUCTION MOTORS

■ 60W □ 90mm



规格 Specs 连续额定 Continuous Rating

型号 Model · 类型 Type		输出功率 Output power W	电压 Voltage V	频率 Frequency Hz	电流 Current A	启动转矩 Starting Torque mN.m	额定转矩 Rated Torque mN.m	额定转速 Rated Speed r/min	电容器容量 Capacitor μF
上段:齿轮轴 Upper:Pinion Shaft 下段()内:圆轴 Below:Round Shaft	带端子箱型 Terminal Box Type 外形图Dimensions②								
导线型 Lead Wire Type 外形图Dimensions①	带端子箱型 Terminal Box Type 外形图Dimensions②								
5IK60GN-AF (5IK60A-AF)	5IK60GN-AFT (5IK60A-AFT)	60	1ph 100	50	1.00	320	470	1250	20.0
				60	1.10		380	1550	
5IK60GN-EF (5IK40A-EF)	5IK60GN-EFT (5IK60A-EFT)	60	1ph 110	60	0.80	300	380	1550	12.0
			1ph 120		0.85				
5IK60GN-CF (5IK60A-CF)	5IK60GN-CFT (5IK60A-CFT)	60	1ph 220	50	0.50	340	470	1250	4.0
			1ph 230		0.55				
5IK60GN-HF (5IK60A-HF)	5IK60GN-HFT (5IK60A-HFT)	60	1ph 220	60	0.50	340	380	1550	
			1ph 230		0.55				
5IK60GN-SF (5IK60A-SF)	5IK60GN-SFT (5IK60A-SFT)	60	3ph 220	50	0.45	1000	470	1250	
				60	0.40	800	380	1550	

- 各种安全规格以电动机铭牌上的型号名取得认证。
When the motor is approved under various safety standards, the model name on the nameplate is the approved model name.
- 注：“-A”型号中电压为110V时，配置电容器容量以实际铭牌为准。
Note:“-A” it means the voltage 110v,the assembly capacitor vaule it is according the labe.

种类 Type

- 电动机 Motor

机型 Type	型号 Model	
	齿轮轴型 Pinion Shaft	圆轴型 Round Shaft
导线型 Lead Wire Type	5IK60GN-AF	5IK60A-AF
	5IK60GN-EF	5IK60A-EF
	5IK60GN-CF	5IK60A-CF
	5IK60GN-HF	5IK60A-HF
	5IK60GN-SF	5IK60A-SF
带端子箱型 Terminal Box Type	5IK60GN-AFT	5IK60A-AFT
	5IK60GN-EFT	5IK60A-EFT
	5IK60GN-CFT	5IK60A-CFT
	5IK60GN-HFT	5IK60A-HFT
	5IK60GN-SFT	5IK60A-SFT

- 平行轴减速器（另售） Parallel Shaft Gearhead (Sold Separately)

减速器种类 Gearhead Type	减速器型号 Gearhead Model	减速比 Gear Ratio
长寿命●低噪音 Long Life ● Low Noise	5GN□K	3、3.6、5、6、7.5、9、12.5、15、18、25、30、36、50、60、75、90、100、120、150、180、200
	5GN10XK (中间减速器 Decimal Gearhead)	

- 减速器型号的□中为减速比的数值
Enter the gear ratio in the box (□) within the model name

■ 装有减速器时的容许转矩 Gear Motor-Torque Table

- 减速器另售·中间减速器另售。电动机型号的□中为表示带端子箱型的记号(T)。
Gearhead and mid-gearbox can be sold separately. Enter the code that represents the terminal box type (T) in the box (□) within the model name.
- 减速品型号的□中为减速比的数值。
Enter the gear ratio in the box(□) within the model name.
- □色表示与电动机同一方向运转，其他则为相反方向。
The colored background □ indicates the same rotating direction of the motor while the rotating direction of others are opposite.
- 转速是以电动机的同步转速 (50Hz : 1500r/min、60Hz : 1800r/min) 为基准除以减速比而算出来的数值。实际转速将随负载大小变化所示数值减少2%~20%左右。
The speed is calculated by dividing the motor's synchronous speed(50Hz : 1500r/min、60Hz : 1800r/min) by the gear ratio. The actual speed is 2%~20% less than the displayed value, depending on the size of the load.
- 希望以大于下表的减速比进行进一步减速时，可在电动机与减速机之间安装减速比为10的中间减速机。这时的容许转矩为10N·m。
To reduce the speed beyond the gear ratio in the table, attach a decimal gearhead(gear ratio:10)between the gearhead and motor. In that case, the permissible torque is 10N·m.

■ 容许力矩单位 Allowance Torque Unit : 上段 Upside (N.m) /下段 Belowside (kgf.cm)

类型 Type 电动机/减速机 Motor/Gearhead	减速比 Gear Ratio		3	3.6	5	6	7.5	9	12.5	15	18	25	30	36	50	60	75	90	100	120	150	180	200
	转速 Speed r/min	50Hz	500	417	300	250	200	166	120	100	83	60	50	41	30	25	20	16	15	12.5	10	8.3	7.5
5IK60GN-AF□ 5IK60GN-EF□ 5IK60GN-CF□ 5IK60GN-HF□ 5IK60GN-SF□	5GN□K	50Hz	1.1	1.4	1.9	2.3	2.9	3.4	4.8	5.7	6.8	8.6	10	10	10	10	10	10	10	10	10	10	10
		60Hz	11.2	14.2	19.3	23.4	29.6	34.7	48.9	58.1	69.3	87.7	100	100	100	100	100	100	100	100	100	100	100
	5GN□K	50Hz	0.92	1.1	1.5	1.8	2.3	2.8	3.8	4.6	5.5	6.9	8.3	10	10	10	10	10	10	10	10	10	10
		60Hz	9.38	11.2	15.3	18.3	23.4	28.5	38.7	46.9	56.1	70.1	84.7	100	100	100	100	100	100	100	100	100	100

■ 容许悬挂负载 · 容许轴向负载 To Allow The Hoisting Of The Load Allow Axial Load

电动机 (圆轴型) → 272页 Motor(Round Shaft) → P272
减速机 → 272页 Gearhead → P272

■ 减速机的容许负载惯性惯量 J Permissible Load Inertia J For Gearhead

→ 272页 → P272

■ 外形图 (单位 mm) Dimensions(Unit mm)

减速机附有安装用螺丝 Mounting screws are included with gearhead.

● 导线型 Lead Wiring Type ①

重量 Weight : 电动机 Motor : 2.7kg 减速机 Gearhead : 1.35kg

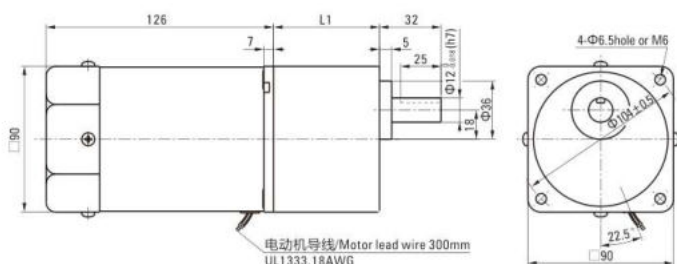

电动机型号 Motor Model	减速器型号 Gearhead Model	减速比 Gear Ratio	L1
5IK60GN-AF 5IK60GN-EF 5IK60GN-CF	5GN□K	3~18	42
5IK60GN-HF 5IK60GN-SF		25~200	60

- 减速器型号的□中为减速比的数值
Enter the gear ratio in the box (□) within the model name

● 带端子箱型 Terminal Box Type ②

重量 Weight : 电动机 Motor : 2.85kg

减速器 Gearhead : 1.35kg

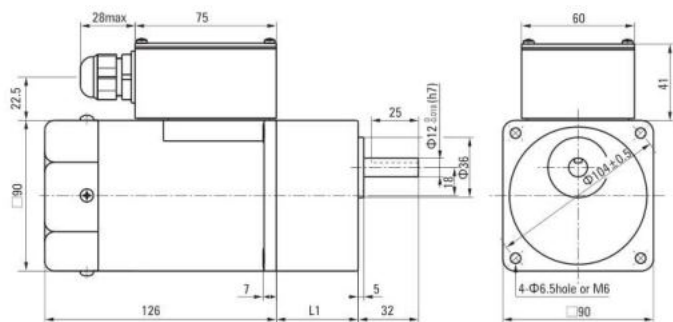

● 键 · 键槽 (减速器附件) Key · Keyway(Accessory Of Gearhead)

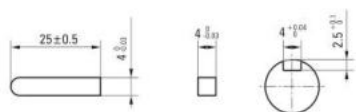

● 圆轴型的转轴部分 Shaft Section Of Round Shaft Type

除重量及轴部外电动机外形与齿轮轴型相同。
Excluding weight and the shaft section motor shape are the same as those of the pinion shaft type.

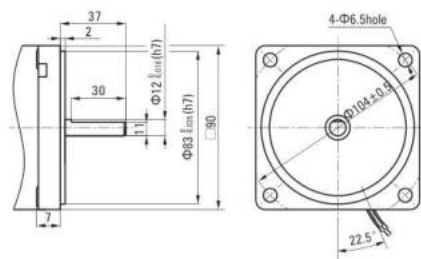

■ 电容器外形尺寸 Formal Dimension Of Capacitor

型号 Model		电容器型号 Capacitor Model	L	W	H
齿轮轴型 Pinion Shaft	圆轴型 Round Shaft				
5IK60GN-AF□	5IK60A-AF□	ZD200CFAUL	47	23	35
5IK60GN-EF□	5IK60A-EF□	ZD120CFAUL	47	17	31
5IK60GN-CF□	5IK60A-CF□	ZD40BFAUL	47	17	31

● 常规电容器出线为引线,也可根据客户要求配置插片式187#

Note: Conventional capacitor is a lead wire type. Inserted 187# is optional

● 电动机型号的□中为表示带端子箱型的记号(T)

Enter the code that represents the terminal box type (T) in the box (□) within the model name

电动机型号 Motor Model	减速器型号 Gearhead Model	减速比 Gear Ratio	L1
5IK60GN-AFT	5GN□K	3~18	42
5IK60GN-EFT			
5IK60GN-HFT		25~200	60
5IK60GN-SFT			

● 减速器型号的□中为减速比的数值

Enter the gear ratio in the box (□) within the model name

● 中间减速器 Decimal Gearhead

可安装在GN齿轮轴型上 Can be connected to GN pinion shaft type
电动机外形与齿轮轴型相同
5GN10XK

重量 Weight : 0.6kg

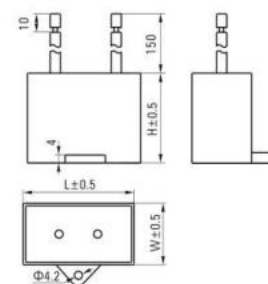
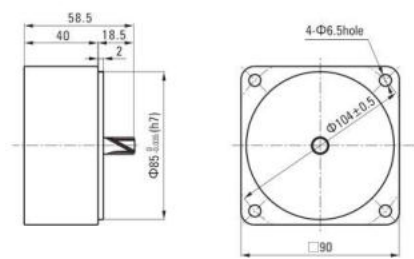

连接图 Wiring Diagram

- 运转方向指从电动机轴看来的方向。CW表示顺时针方向，CCW表示逆时针方向。

The direction of motor rotation is as viewed from the shaft end of motor. CW represents the clockwise direction, while CCW represents the counterclockwise direction.

- 表中所记品名为齿轮轴型，圆轴型亦同。

Name indicated in the list is pinion shaft type, also valid for the equivalent round shaft type.

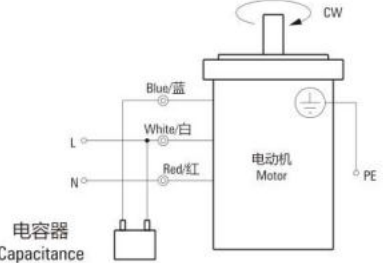
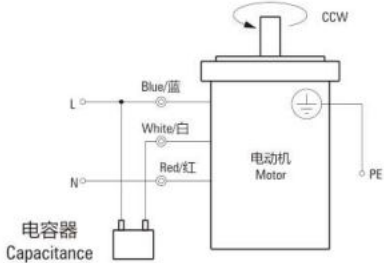
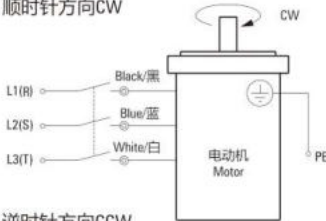
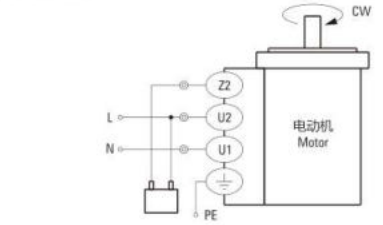
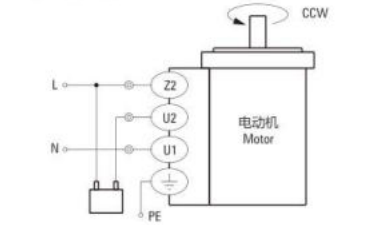
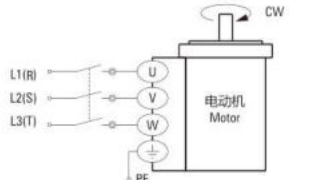
导线型 Lead Wire Type		
5IK60GN-AF、5IK60GN-EF、5IK60GN-HF、5IK60GN-CF		5IK60GN-SF
顺时针方向CW  <p>电容器 Capacitance</p>	逆时针方向CCW  <p>电容器 Capacitance</p>	顺时针方向CW  <p>逆时针方向CCW 若对换R、S、T中任意二条，电动机会作逆时针方向运转 To change the rotation direction change any two connections among R, S and T</p>
带端子箱型 Terminal Box Type		
5IK60GN-AFT、5IK60GN-EFT、5IK60GN-HFT、5IK60GN-CFT		5IK60GN-SFT
顺时针方向CW  <p>电容器 Capacitance</p>	逆时针方向CCW  <p>电容器 Capacitance</p>	顺时针方向CW  <p>逆时针方向CCW 若对换U、V、W中任意二条，电动机会作逆时针方向运转 To change the rotation direction change any two connections among U, V and W</p>

请注意 Note:

单相电动机运转方向的转换应在电动机停止后进行。

Change the direction of single-phase motor rotation only after bring the motor to a stop.

若在电动机运转时转换运转方向，可能发生无法转换运转方向或须费时较久的情况。

If an attempt is made to change the direction of rotation while the motor is rotating, motor may ignore reversing command or change its direction of rotation after some delay.

感应电动机 INDUCTION MOTORS

■ 60W □ 90mm

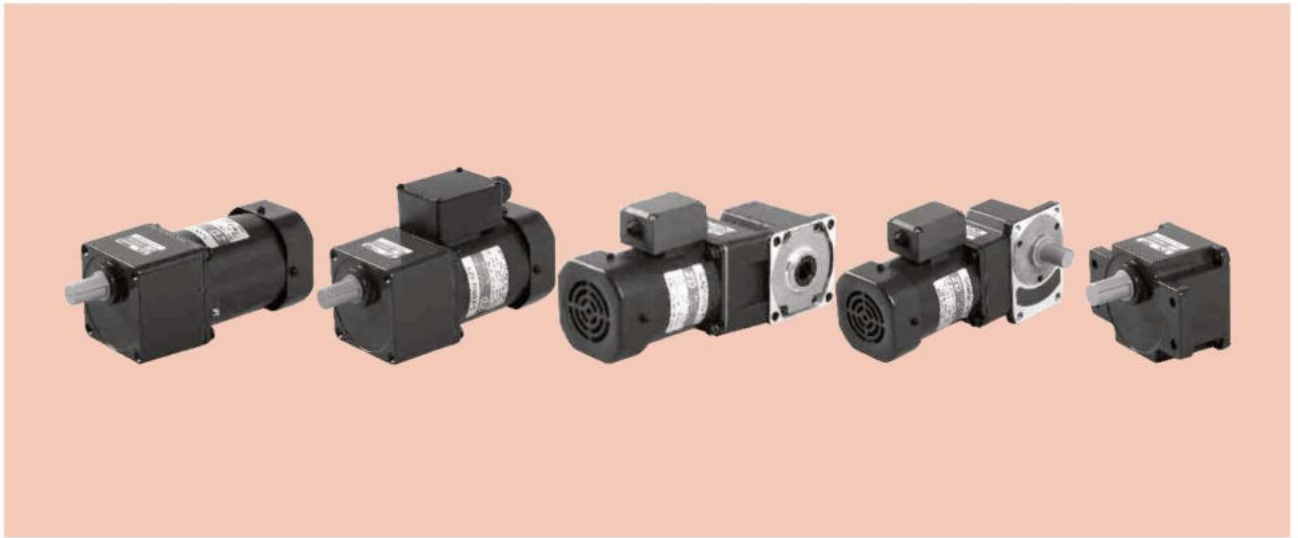

规格 Specs 连续额定 Continuous Rating

型号 Model · 类型 Type		输出功率 Output power W	电压 Voltage V	频率 Frequency Hz	电流 Current A	启动转矩 Starting Torque mN.m	额定转矩 Rated Torque mN.m	额定转速 Rated Speed r/min	电容器容量 Capacitor μF
上段:齿轮轴 Upper:Pinion Shaft 下段():内:圆轴 Below:Round Shaft	带端子箱型 Terminal Box Type 外形图Dimensions②								
导线型 Lead Wire Type 外形图Dimensions①	带端子箱型 Terminal Box Type 外形图Dimensions②								
5IK60GU-AF	5IK60GU-AFT	60	1ph 100	50	1.00	320	470	1250	20.0
				60	1.10		380	1550	
5IK60GU-EF	5IK60GU-EFT	60	1ph 110 1ph 120	60	0.80	300	380	1550	12.0
					0.85				
5IK60GU-CF	5IK60GU-CFT	60	1ph 220 1ph 230	50	0.50	340	470	1250	4.0
					0.55				
5IK60GU-HF	5IK60GU-HFT	60	1ph 220 1ph 230	60	0.50	340	380	1550	-
					0.55				
5IK60GU-SF	5IK60GU-SFT	60	3ph 220	50	0.45	1000	470	1250	-
				60	0.40	800	380	1550	

●各种安全规格以电动机铭牌上的型号名取得认证。

When the motor is approved under various safety standards, the model name on the nameplate is the approved model name.

●注：“-A”型号中电压为110V时，配置电容器容量以实际铭牌为准。

Note:“-A” it means the voltage 110V,the assembly capacitor vaule it is according the labe.

种类 Type

● 电动机 Motor

机型 Type	型号 Model
	齿轮轴型 Pinion Shaft
导线型 Lead Wire Type	5IK60GU-AF
	5IK60GU-EF
	5IK60GU-CF
	5IK60GU-HF
	5IK60GU-SF
带端子箱型 Terminal Box Type	5IK60GU-AFT
	5IK60GU-EFT
	5IK60GU-CFT
	5IK60GU-HFT
	5IK60GU-SFT

● 平行轴减速器（另售） Parallel Shaft Gearhead (Sold Separately)

减速器种类 Gearhead Type	减速器型号 Gearhead Model	减速比 Gear Ratio
长寿命●低噪音 Long Life ● Low Noise	5GU□KB	3、3.6、5、6、7.5、9、 12.5、15、18、25、30、 36、50、60、75、90、 100、120、150、180、200
	5GU10XK (中间减速器 Decimal Gearhead)	

●减速器型号的□中为减速比的数值

Enter the gear ratio in the box (□) within the model name

■ 装有减速器时的容许转矩 Gear Motor-Torque Table

- 减速器另售·中间减速器另售。电动机型号的□中为表示带端子箱型的记号(T)。
Gearhead and mid-gearbox can be sold separately. Enter the code that represents the terminal box type (T) in the box (□) within the model name.
- 减速品型号的□中为减速比的数值。
Enter the gear ratio in the box(□) within the model name.
- □色表示与电动机同一方向运转，其他则为相反方向。
The colored background □ indicates the same rotating direction of the motor while the rotating direction of others are opposite.
- 转速是以电动机的同步转速 (50Hz : 1500r/min、60Hz : 1800r/min) 为基准除以减速比而算出来的数值。实际转速将随负载大小变化所示数值减少2%~20%左右。
The speed is calculated by dividing the motor's synchronous speed(50Hz : 1500r/min、60Hz : 1800r/min) by the gear ratio. The actual speed is 2%~20% less than the displayed value, depending on the size of the load.
- 希望以大于下表的减速比进行进一步减速时，可在电动机与减速机之间安装减速比为10的中间减速机。这时的容许转矩为20N·m。
To reduce the speed beyond the gear ratio in the table, attach a decimal gearhead(gear ratio:10)between the gearhead and motor. In that case, the permissible torque is 20N·m.

■ 容许力矩单位 Allowance Torque Unit : 上段 Upside (N.m) /下段 Belowside (kgf.cm)

类型 Type 电动机/减速机 Motor/Gearhead	减速比 Gear Ratio		3	3.6	5	6	7.5	9	12.5	15	18	25	30	36	50	60	75	90	100	120	150	180	200
	转速 Speed r/min	50Hz	500	417	300	250	200	166	120	100	83	60	50	41	30	25	20	16	15	12.5	10	8.3	7.5
5IK60GU-AF□ 5IK60GU-EF□ 5IK60GU-CF□ 5IK60GU-HF□ 5IK60GU-SF□	50Hz	500	1.1	1.4	1.9	2.3	2.9	3.4	4.8	5.7	6.8	8.6	10	10.3	12.4	15.5	18.6	20	20	20	20	20	20
		600	11.2	14.2	19.3	23.4	29.6	34.7	48.9	58.1	69.3	87.7	100	105	126	158	189	200	200	200	200	200	200
	60Hz	500	0.92	1.1	1.5	1.8	2.3	2.8	3.8	4.6	5.5	6.9	8.3	8.3	10	12.5	15	18.8	20	20	20	20	20
		600	9.38	11.2	15.3	18.3	23.4	28.5	38.7	46.9	56.1	70.1	84.7	84.6	102	127	153	192	200	200	200	200	200

■ 容许悬挂负载 · 容许轴向负载 To Allow The Hoisting Of The Load Allow Axial Load

电动机 (圆轴型) → 272页 Motor(Round Shaft) → P272
减速机 → 272页 Gearhead → P272

■ 减速机的容许负载惯性惯量 J Permissible Load Inertia J For Gearhead

→ 272页 → P272

■ 外形图 (单位 mm) Dimensions(Unit mm)

减速器附有安装用螺丝 Mounting screws are included with gearhead.

● 导线型 Lead Wiring Type ①

重量 Weight : 电动机 Motor : 2.7kg 减速器 Gearhead : 1.35kg

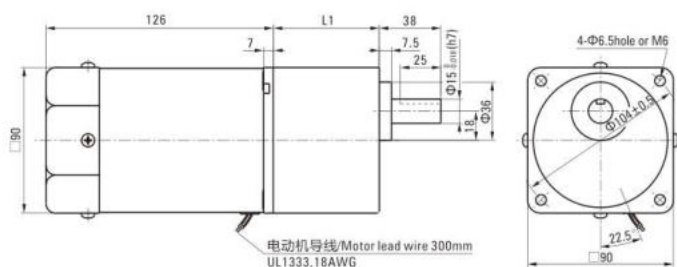

电动机型号 Motor Model	减速器型号 Gearhead Model	减速比 Gear Ratio	L1
5IK60GU-AF 5IK60GU-EF 5IK60GU-CF 5IK60GU-HF 5IK60GU-SF	5GU□KB	3~200	65.5

- 减速器型号的□中为减速比的数值
Enter the gear ratio in the box (□) within the model name

● 带端子箱型 Terminal Box Type ②

重量 Weight : 电动机 Motor : 2.85kg

减速器 Gearhead : 1.5kg

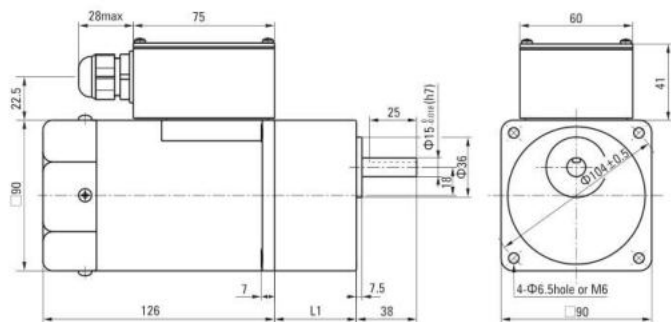

●适用电缆直径为 Use cable with a diameter of $\Phi 6 \sim \Phi 12$ mm

● 凸缘安装型减速器 Flange Mounting Reducer

可安装在GU齿轮轴型上

Can be mounted on GU type gear shaft

5GU□K

重量Weight:1.5kg

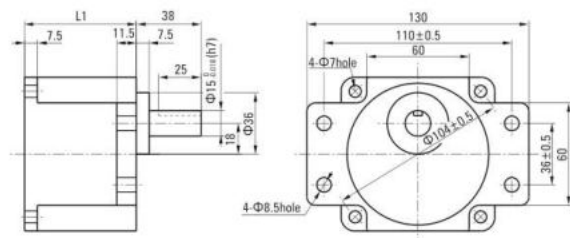

● 圆轴型的转轴部分 Shaft Section Of Round Shaft Type

除重量及轴部外电动机外形与齿轮轴型相同。

Excluding weight and the shaft section motor shape are the same as those of the pinion shaft type.

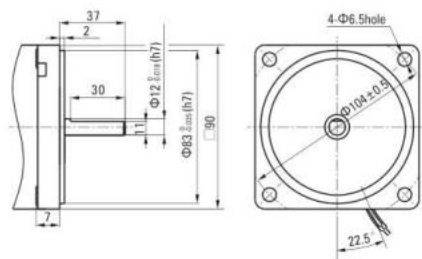

电动机型号 Motor Model	减速器型号 Gearhead Model	减速比 Gear Ratio	L1
5IK60GU-AFT	5GU□KB	3~200	65.5
5IK60GU-EFT			
5IK60GU-CFT			
5IK60GU-HFT			
5IK60GU-SFT			

●减速器型号的□中为减速比的数值
Enter the gear ratio in the box (□) within the model name

● 键·键槽 (减速器附件)

Key · Keyway(Accessory Of Gearhead)

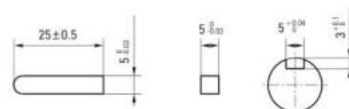

● 中间减速器 Decimal Gearhead

可安装在GU齿轮轴型上 Can be connected to GU pinion shaft type

电动机外形与齿轮轴型相同

5GU10XK

重量 Weight : 0.65kg

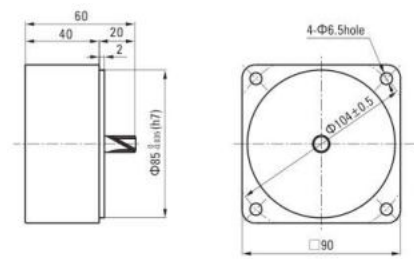

■ 电容器外形尺寸 Formal Dimension Of Capacitor

型号Model	电容器型号 Capacitor Model	L	W	H
5IK60GU-AF□	ZD200CFAUL	47	23	35
5IK60GU-EF□	ZD120CFAUL	47	17	31
5IK60GU-CF□	ZD40BFAUL	47	17	31

● 常规电容器出线为引线,也可根据客户要求配置插片式187#

Note: Conventional capacitor is a lead wire type. Inserted 187# is optional

● 电动机型号的□中为表示带端子箱型的记号(T)

Enter the code that represents the terminal box type (T) in the box (□) within the model name

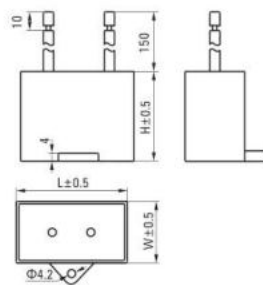

弧锥直角 SPIRAL BEVEL RIGHT ANGLE

■ 装有减速器时的容许转矩 Gear Motor-Torque Table

- 减速器 中间减速器另售。 • 电动机型号的□中为表示带端子箱型的记号(T)。
Gearhead and mid-gearbox can be sold separately. Enter the code that represents the terminal box type (T) in the box (□) within the model name.
- 减速器型号的□中为减速比的数值。 □ 色表示与电动机同一方向运转，其他则为相反方向。
Enter the gear ratio in the box (□) within the model name.
The colored background □ indicates the same rotating direction of the motor while the rotating direction of others are opposite.
- 转速是以电动机的同步转速 (50Hz:1500r/min、60Hz:1800r/min) 为基准除以减速比而算出来的数值。实际转速将随负载大小变化而比所示数值减少2%~20%左右。
The speed is calculated by dividing the motor's synchronous speed (50Hz:1500r/min、60Hz:1800r/min) by the gear ratio. The actual speed is 2%~20% less than the displayed value, depending on the size of the load.
- 希望以大于下表的减速比进行进一步减速时，可在电动机与减速器之间安装减速比为10的中间减速器。这时的容许转矩为20N·m。
To reduce the speed beyond the gear ratio in the table, attach a mid-gearbox (gear ratio:10) between the gearhead and motor. In that case, the permissible torque is 20N·m.

■ 容许力矩单位 Allowance Torque Unit: 上段 Upside (N.m) / 下段 Belowside (kgf.cm)

机型Type 电动机/减速器 Motor/Gearhead	减速比Gear Ratio	容许力矩 Allowance Torque																				
		3	3.6	5	6	7.5	9	12.5	15	18	25	30	36	50	60	75	90	100	120	150	180	
5IK60GU-AF□ 5IK60GU-EF□ 5IK60GU-CF□ 5IK60GU-HF□ 5IK60GU-SF□	5GU□RC 5GU□RT	50Hz	0.85	1.02	1.42	1.70	2.37	2.84	3.95	4.73	5.68	7.89	9.47	10.2	14.2	17.0	20.0	20.0	20.0	20.0	20.0	20.0
		60Hz	0.69	0.82	1.15	1.37	1.91	2.29	3.18	3.82	4.58	6.36	7.64	8.25	11.5	13.7	17.2	20.0	20.0	20.0	20.0	20.0

■ 感应尺寸图 Induction Type Drawing

5IK60GU-AF□/5GU□RC 5IK60GU-EF□/5GU□RC	5IK60GU-CF□/5GU□RC 5IK60GU-HF□/5GU□RC	5IK60GU-SF□/5GU□RC	5IK60GU-AF□/5GU□RT 5IK60GU-EF□/5GU□RT	5IK60GU-CF□/5GU□RT 5IK60GU-HF□/5GU□RT	5IK60GU-SF□/5GU□RT
--	--	--------------------	--	--	--------------------

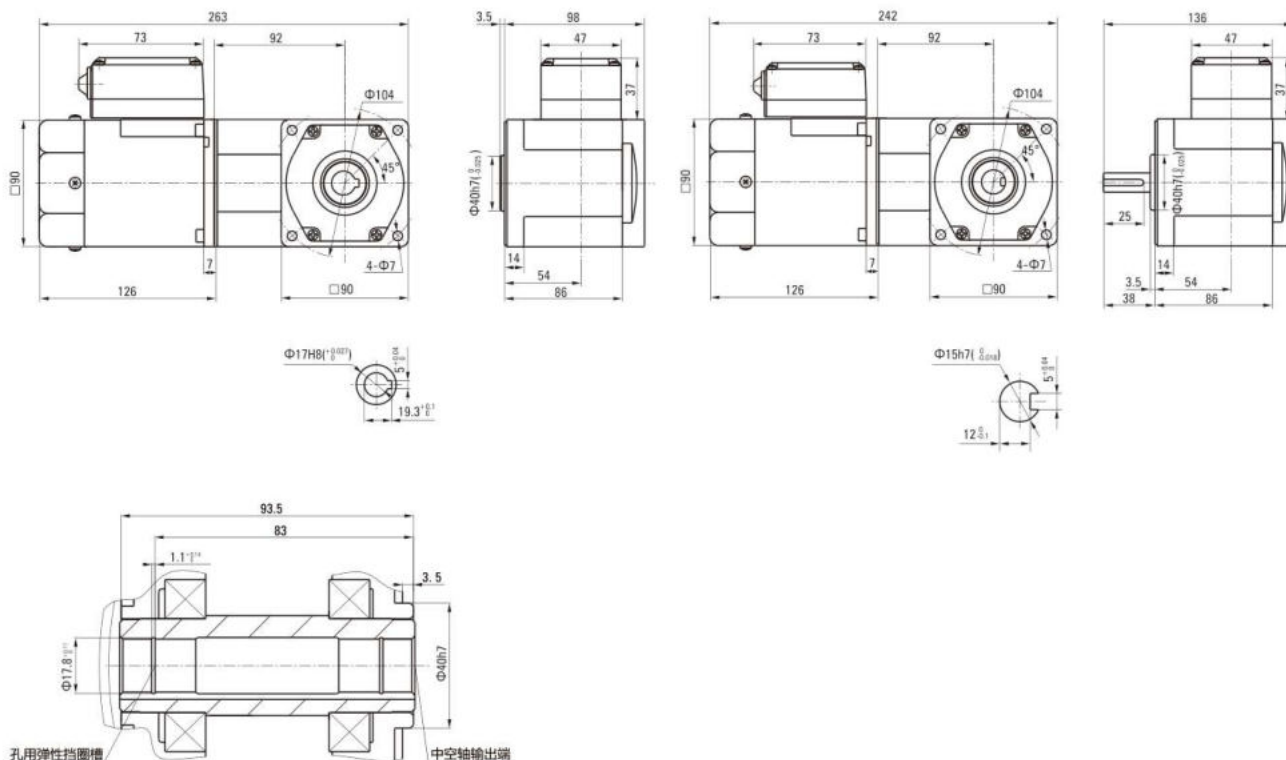

■ 连接图 Wiring Diagram

- 运转方向指从电动机轴看来的方向。CW表示顺时针方向，CCW表示逆时针方向。
The direction of motor rotation is as viewed from the shaft end of motor. CW represents the clockwise direction, while CCW represents the counterclockwise direction.
- 表中所记品名为齿轮轴型，圆轴型亦同。
Name indicated in the list is pinion shaft type, also valid for the equivalent round shaft type.

导线型 Lead Wire Type		
5IK60GU-AF、5IK60GU-EF、5IK60GU-HF、5IK60GU-CF		5IK60GU-SF
<p>顺时针方向CW</p> <p>电容器 Capacitance</p>	<p>逆时针方向CCW</p> <p>电容器 Capacitance</p>	<p>顺时针方向CW</p> <p>逆时针方向CCW 若对换R、S、T中任意二条，电动机会作逆时针方向运转 To change the rotation direction change any two connections among R, S and T</p>
带端子箱型 Terminal Box Type		
5IK60GU-AFT、5IK60GU-EFT、5IK60GU-HFT、5IK60GU-CFT		5IK60GU-SFT
<p>顺时针方向CW</p> <p>电容器 Capacitance</p>	<p>逆时针方向CCW</p> <p>电容器 Capacitance</p>	<p>顺时针方向CW</p> <p>逆时针方向CCW 若对换U、V、W中任意二条，电动机会作逆时针方向运转 To change the rotation direction change any two connections among U, V and W</p>

请注意 Note:

单相电动机运转方向的转换应在电动机停止后进行。

Change the direction of single-phase motor rotation only after bring the motor to a stop.

若在电动机运转时转换运转方向，可能发生无法转换运转方向或须费时较久的情况。

If an attempt is made to change the direction of rotation while the motor is rotating, motor may ignore reversing command or change its direction of rotation after some delay.

感应电动机 INDUCTION MOTORS

■ 90W □ 90mm

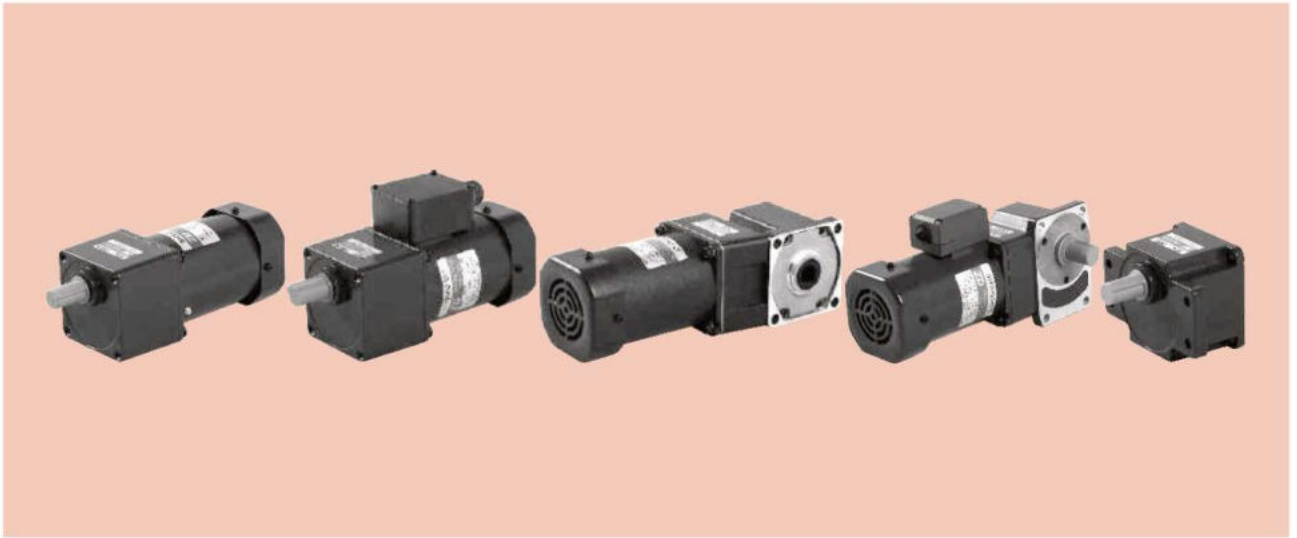

规格 Specs 连续额定 Continuous Rating

型号Model · 类型 Type		输出功率 Output power W	电压 Voltage V	频率 Frequency Hz	电流 Current A	启动转矩 Starting Torque mN.m	额定转矩 Rated Torque mN.m	额定转速 Rated Speed r/min	电容器容量 Capacitor μF
上段:齿轮轴 Upper:Pinion Shaft 下段()内:圆轴 Below:Round Shaft	带端子箱型 Terminal Box Type 外形图Dimensions②								
导线型 Lead Wire Type 外形图Dimensions①	带端子箱型 Terminal Box Type 外形图Dimensions②								
5IK90GU-AF (5IK90A-AF)	5IK90GU-AFT (5IK90A-AFT)	90	1ph 100	50	1.55	450	700	1250	25.0
				60	1.85		570	1550	
5IK90GU-EF (5IK90A-EF)	5IK90GU-EFT (5IK90A-EFT)	90	1ph 110	60	1.40	500	570	1550	20.0
			1ph 120		1.45				
5IK90GU-CF (5IK90A-CF)	5IK90GU-CFT (5IK90A-CFT)	90	1ph 220	50	0.72	450	700	1250	5.0
			1ph 230		0.70				
5IK90GU-HF (5IK90A-HF)	5IK90GU-HFT (5IK90A-HFT)	90	1ph 220	60	0.71	450	570	1550	
			1ph 230		0.75				
5IK90GU-SF (5IK90A-SF)	5IK90GU-SFT (5IK90A-SFT)	90	3ph 220	50	0.60	1350	700	1250	
				60	0.55				

●各种安全规格以电动机铭牌上的型号名取得认证。

When the motor is approved under various safety standards, the model name on the nameplate is the approved model name.

●注：“-A”型号中电压为110V时，配置电容器容量以实际铭牌为准。

Note:“-A” it means the voltage 110V,the assembly capacitor vaule it is according the labe.

种类 Type

● 电动机 Motor

机型 Type	型号Model	
	齿轮轴型 Pinion Shaft	圆轴型 Round Shaft
导线型 Lead Wire Type	5IK90GU-AF	5IK90A-AF
	5IK90GU-EF	5IK90A-EF
	5IK90GU-CF	5IK90A-CF
	5IK90GU-HF	5IK90A-HF
	5IK90GU-SF	5IK90A-SF
带端子箱型 Terminal Box Type	5IK90GU-AFT	5IK90A-AFT
	5IK90GU-EFT	5IK90A-EFT
	5IK90GU-CFT	5IK90A-CFT
	5IK90GU-HFT	5IK90A-HFT
	5IK90GU-SFT	5IK90A-SFT

● 平行轴减速器（另售） Parallel Shaft Gearhead (Sold Separately)

减速器种类 Gearhead Type	减速器型号 Gearhead Model	减速比 Gear Ratio
长寿命●低噪音 Long Life ● Low Noise	5GU□KB	3、3.6、5、6、7.5、9、12.5、15、18、25、30、36、50、60、75、90、100、120、150、180、200
	5GU10XK (中间减速器 Decimal Gearhead)	

●减速器型号的□中为减速比的数值

Enter the gear ratio in the box (□) within the model name

● 带端子箱型 Terminal Box Type ②

重量 Weight : 电动机 Motor : 3.35kg

减速器 Gearhead : 1.5kg

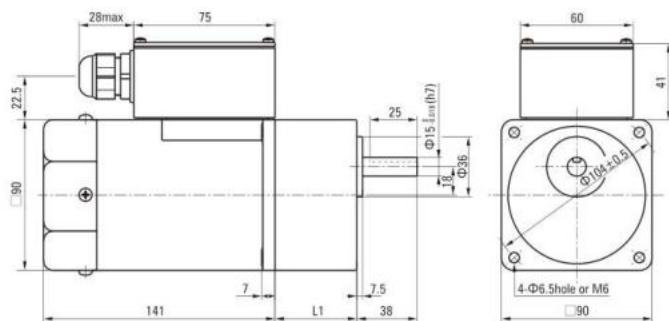

●适用电缆直径为 Use cable with a diameter of $\Phi 6 \sim \Phi 12$ mm

电动机型号 Motor Model	减速器型号 Gearhead Model	减速比 Gear Ratio	L1
5IK90GU-AFT 5IK90GU-EFT 5IK90GU-CFT 5IK90GU-HFT 5IK90GU-SFT	5GU□KB	3~200	65.5

●减速器型号的□中为减速比的数值
Enter the gear ratio in the box (□) within the model name

● 凸缘安装型减速器 Flange Mounting Reducer

可安装在GU齿轮轴型上

Can be mounted on GU type gear shaft

5GU□K

重量Weight:1.5kg

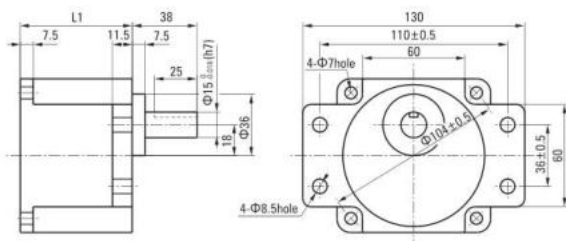

● 键·键槽 (减速器附件)

Key · Keyway(Accessory Of Gearhead)



● 圆轴型的转轴部分 Shaft Section Of Round Shaft Type

除重量及轴部外电动机外形与齿轮轴型相同。

Excluding weight and the shaft section motor shape are the same as those of the pinion shaft type.

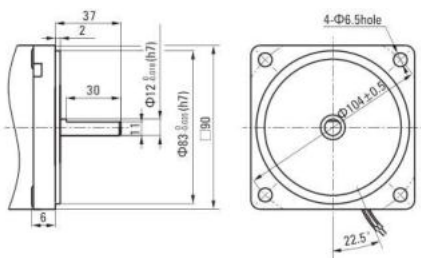

● 中间减速器 Decimal Gearhead

可安装在GU齿轮轴型上 Can be connected to GU pinion shaft type
电动机外形与齿轮轴型相同

5GU10XK

重量 Weight : 0.65kg

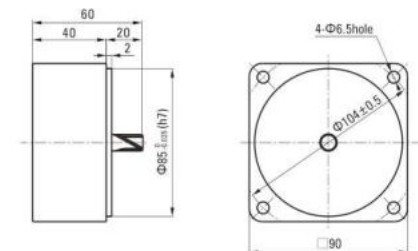

■ 电容器外形尺寸 Formal Dimension Of Capacitor

型号 Model		电容器型号 Capacitor Model	L	W	H
齿轮轴型 Pinion Shaft	圆轴型 Round Shaft				
5IK90GU-AF□	5IK90A-AF□	ZD250CFAUL	47	27	37
5IK90GU-EF□	5IK90A-EF□	ZD200CFAUL	47	23	35
5IK90GU-CF□	5IK90A-CF□	ZD50BFAUL	47	20	31

● 常规电容器出线为引线,也可根据客户要求配置插片式187#

Note: Conventional capacitor is a lead wire type. Inserted 187# is optional

● 电动机型号的□中为表示带端子箱型的记号(T)

Enter the code that represents the terminal box type (T) in the box (□) within the model name

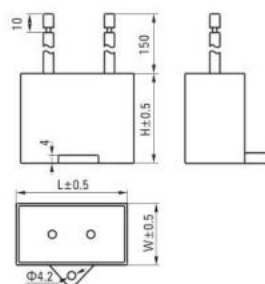

弧锥直角 SPIRAL BEVEL RIGHT ANGLE

■ 装有减速器时的容许转矩 Gear Motor-Torque Table

- 减速器 中间减速器另售。 • 电动机型号的□中为表示带端子箱型的记号(T)。
Gearhead and mid-gearbox can be sold separately. Enter the code that represents the terminal box type (T) in the box (□) within the model name.
- 减速器型号的□中为减速比的数值。 □ 色表示与电动机同一方向运转，其他则为相反方向。
Enter the gear ratio in the box (□) within the model name.
The colored background □ indicates the same rotating direction of the motor while the rotating direction of others are opposite.
- 转速是以电动机的同步转速 (50Hz:1500r/min、60Hz:1800r/min) 为基准除以减速比而算出来的数值。实际转速将随负载大小变化而比所示数值减少2%~20%左右。
The speed is calculated by diving the motor's synchronous speed (50Hz:1500r/min、60Hz:1800r/min) by the gear ratio. The actual speed is 2%~20% less than the displayed value, depending on the size of the load.
- 希望以大于下表的减速比进行进一步减速时，可在电动机与减速器之间安装减速比为10的中间减速器。这时的容许转矩为20N·m。
To reduce the speed beyond the gear ratio in the table, attach a mid-gearbox (gear ratio:10) between the gearhead and motor. In that case, the permissible torque is 20N·m.

■ 容许力矩单位 Allowance Torque Unit: 上段 Upside (N.m) / 下段 Belowside (kgf.cm)

机型Type 电动机/减速器 Motor/Gearhead	减速比Gear Ratio	容许力矩 Allowance Torque																				
		3	3.6	5	6	7.5	9	12.5	15	18	25	30	36	50	60	75	90	100	120	150	180	
5IK90GU-AF□ 5IK90GU-EF□ 5IK90GU-CF□ 5IK90GU-HF□ 5IK90GU-SF□	5GU□RC 5GU□RT	50Hz	500	417	300	250	200	166	120	100	83	60	50	42	30	25	20	16	15	12	10	8
		60Hz	600	500	360	300	240	200	144	120	100	72	60	50	36	30	24	20	18	15	12	10
5IK90GU-AF□ 5IK90GU-EF□ 5IK90GU-CF□ 5IK90GU-HF□ 5IK90GU-SF□	5GU□RC 5GU□RT	50Hz	1.28	1.53	2.13	2.56	3.55	4.26	5.92	7.10	8.52	11.8	14.2	15.3	20.0	20.0	20.0	20.0	20.0	20.0	20.0	20.0
		60Hz	1.03	1.24	1.72	2.06	2.86	3.44	4.77	5.73	6.87	9.54	11.5	12.4	17.2	20.0	20.0	20.0	20.0	20.0	20.0	20.0

■ 感应尺寸图 Induction Type Drawing

5IK90GU-AF□/5GU□RC 5IK90GU-EF□/5GU□RC	5IK90GU-CF□/5GU□RC 5IK90GU-HF□/5GU□RC	5IK90GU-SF□/5GU□RC	5IK90GU-AF□/5GU□RT 5IK90GU-EF□/5GU□RT	5IK90GU-CF□/5GU□RT 5IK90GU-HF□/5GU□RT	5IK90GU-SF□/5GU□RT
--	--	--------------------	--	--	--------------------

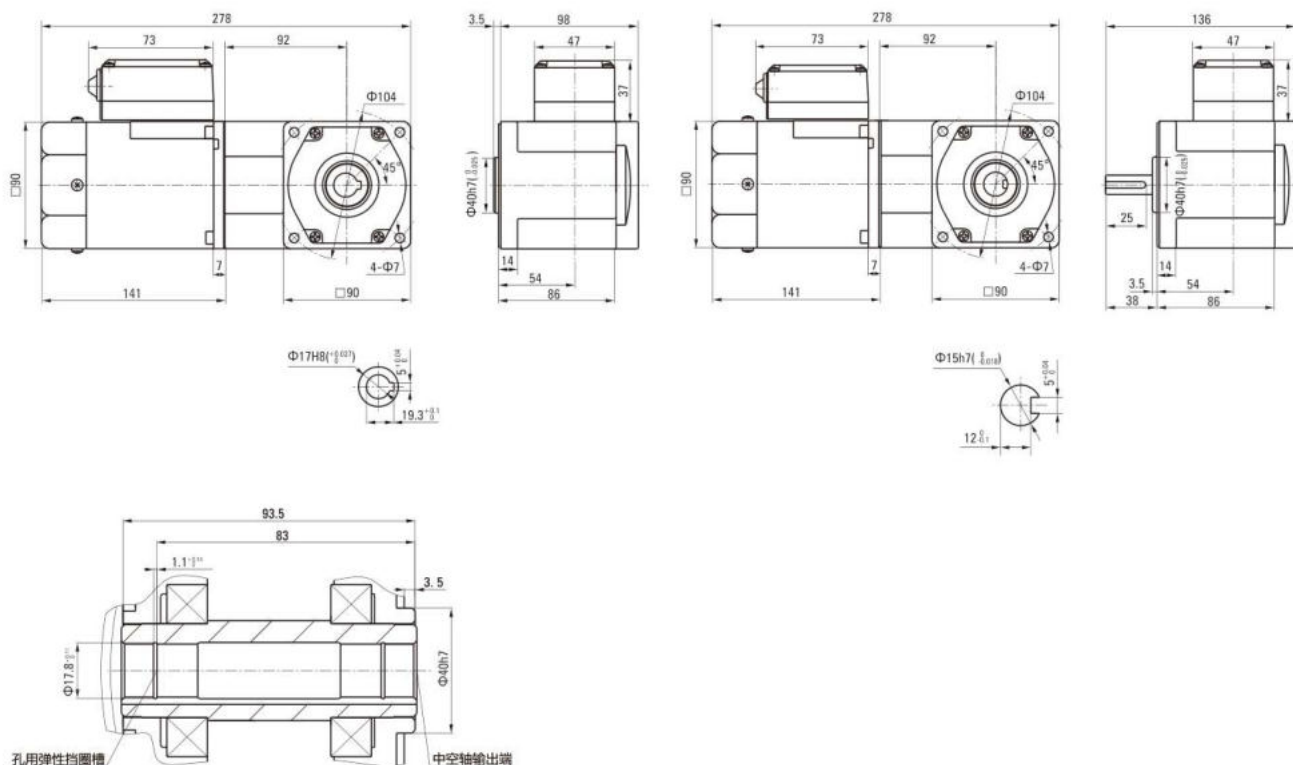

蜗轮蜗杆直角 WORM GEAR RIGHT ANGLE

■ 装有减速器时的容许转矩 Gear Motor-Torque Table

- 减速器-中间减速器另售。• 电动机型号的□中为表示带端子箱型的记号(T)。
Gearhead and mid-gearbox can be sold separately. Enter the code that represents the terminal box type (T) in the box (□) within the model name.
- 减速器型号的□中为减速比的数值。□色表示与电动机同一方向运转，其他则为相反方向。
Enter the gear ratio in the box (□) within the model name.
The colored background □ indicates the same rotating direction of the motor while the rotating direction of others are opposite.
- 转速是以电动机的同步转速 (50Hz:1500r/min、60Hz:1800r/min) 为基准除以减速比而算出来的数值。实际转速将随负载大小变化而比所示数值减少2%~20%左右。
The speed is calculated by dividing the motor's synchronous speed (50Hz:1500r/min、60Hz:1800r/min) by the gear ratio. The actual speed is 2%~20% less than the displayed value, depending on the size of the load.
- 希望以大于下表的减速比进行进一步减速时，可在电动机与减速器之间安装减速比为10的中间减速器。这时的容许转矩为20N·m。
To reduce the speed beyond the gear ratio in the table, attach a mid-gearbox (gear ratio:10) between the gearhead and motor. In that case, the permissible torque is 20N·m.

■ 容许力矩单位 Allowance Torque Unit: 上段 Upside (N.m) / 下段 Belowside (kgf.cm)

机型Type	减速比Gear Ratio	3	3.6	5	6	7.5	9	12.5	15	18	25	30	36	50	60	75	90	100	120	150	180	
电动机/减速器 Motor/Gearhead	转速Speed r/min	50Hz	500	417	300	250	200	166	120	100	83	60	50	42	30	25	20	16	15	12	10	8
	60Hz	600	500	360	300	240	200	144	120	100	72	60	50	36	30	24	20	18	15	12	10	
5IK90GU-AF□ 5IK90GU-EF□ 5IK90GU-CF□ 5IK90GU-HF□ 5IK90GU-SF□	容许力矩 Allowance Torque	50Hz	5GU□RH	0.93	1.11	1.39	1.67	2.09	2.51	3.48	4.18	5.01	6.96	8.35	10.0	13.9	16.7	20.0	20.0	20.0	20.0	20.0
			5GU□RA	9.47	11.4	14.2	17.0	21.3	25.6	35.5	42.6	51.1	71.0	85.2	102	142	170	204	200	200	200	200
	60Hz	5GU□RH	0.75	0.90	1.12	1.35	1.68	2.02	2.81	3.37	4.04	5.61	6.74	8.08	11.2	13.5	16.8	20.0	20.0	20.0	20.0	20.0
		5GU□RA	7.64	9.17	11.5	13.7	17.2	20.6	28.6	34.4	41.2	57.3	68.7	82.5	115	137	172	200	200	200	200	200

■ 感应尺寸图 Induction Type Drawing

5IK90GU-AF□/5GU□RH 5IK90GU-EF□/5GU□RH	5IK90GU-CF□/5GU□RH 5IK90GU-HF□/5GU□RH	5IK90GU-SF□/5GU□RH	5IK90GU-AF□/5GU□RA 5IK90GU-EF□/5GU□RA	5IK90GU-CF□/5GU□RA 5IK90GU-HF□/5GU□RA	5IK90GU-SF□/5GU□RA
--	--	--------------------	--	--	--------------------

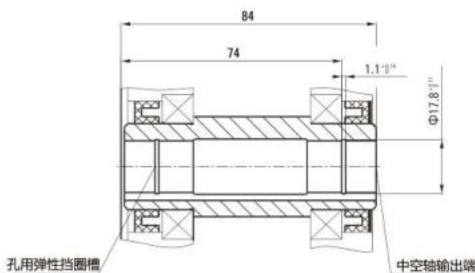
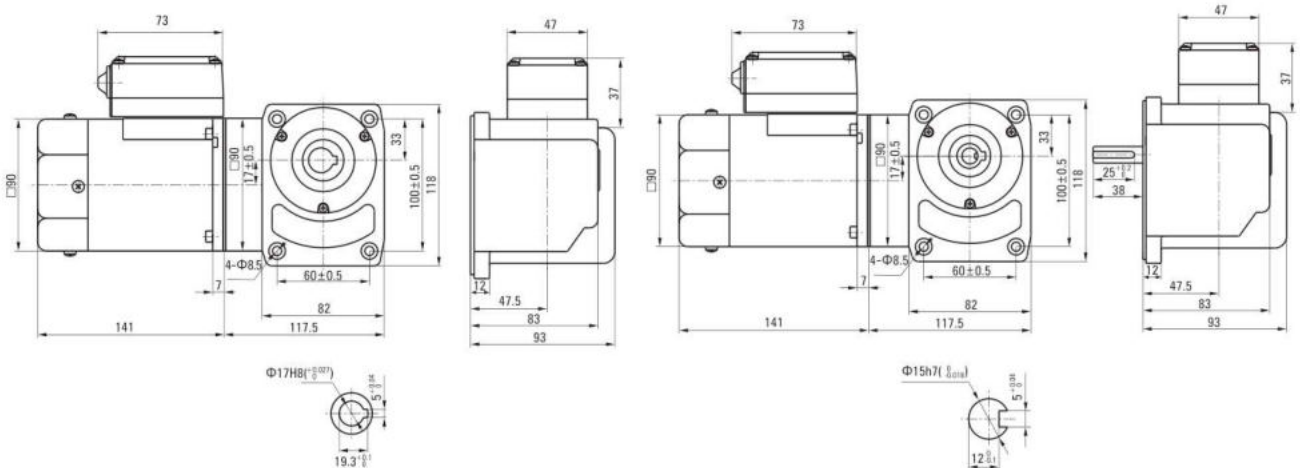

连接图 Wiring Diagram

● 运转方向指从电动机轴看来的方向。CW表示顺时针方向，CCW表示逆时针方向。

The direction of motor rotation is as viewed from the shaft end of motor. CW represents the clockwise direction, while CCW represents the counterclockwise direction.

● 表中所记品名为齿轮轴型，圆轴型亦同。

Name indicated in the list is pinion shaft type, also valid for the equivalent round shaft type.

导线型 Lead Wire Type		
5IK90GU-AF、5IK90GU-EF、5IK90GU-HF、5IK90GU-CF		5IK90GU-SF
<p>顺时针方向CW</p> <p>电容器 Capacitance</p>	<p>逆时针方向CCW</p> <p>电容器 Capacitance</p>	<p>顺时针方向CW</p> <p>逆时针方向CCW 若对换R、S、T中任意二条，电动机会作逆时针方向运转 To change the rotation direction change any two connections among R, S and T</p>
带端子箱型 Terminal Box Type		
5IK90GU-AFT、5IK90GU-EFT、5IK90GU-HFT、5IK90GU-CFT		5IK90GU-SFT
<p>顺时针方向CW</p> <p>电容器 Capacitance</p>	<p>逆时针方向CCW</p> <p>电容器 Capacitance</p>	<p>顺时针方向CW</p> <p>逆时针方向CCW 若对换U、V、W中任意二条，电动机会作逆时针方向运转 To change the rotation direction change any two connections among U, V and W</p>

请注意 Note:

单相电动机运转方向的转换应在电动机停止后进行。

Change the direction of single-phase motor rotation only after bring the motor to a stop.

若在电动机运转时转换运转方向，可能发生无法转换运转方向或须费时较久的情况。

If an attempt is made to change the direction of rotation while the motor is rotating, motor may ignore reversing command or change its direction of rotation after some delay.

感应电动机 INDUCTION MOTORS

■ 120W □ 90mm

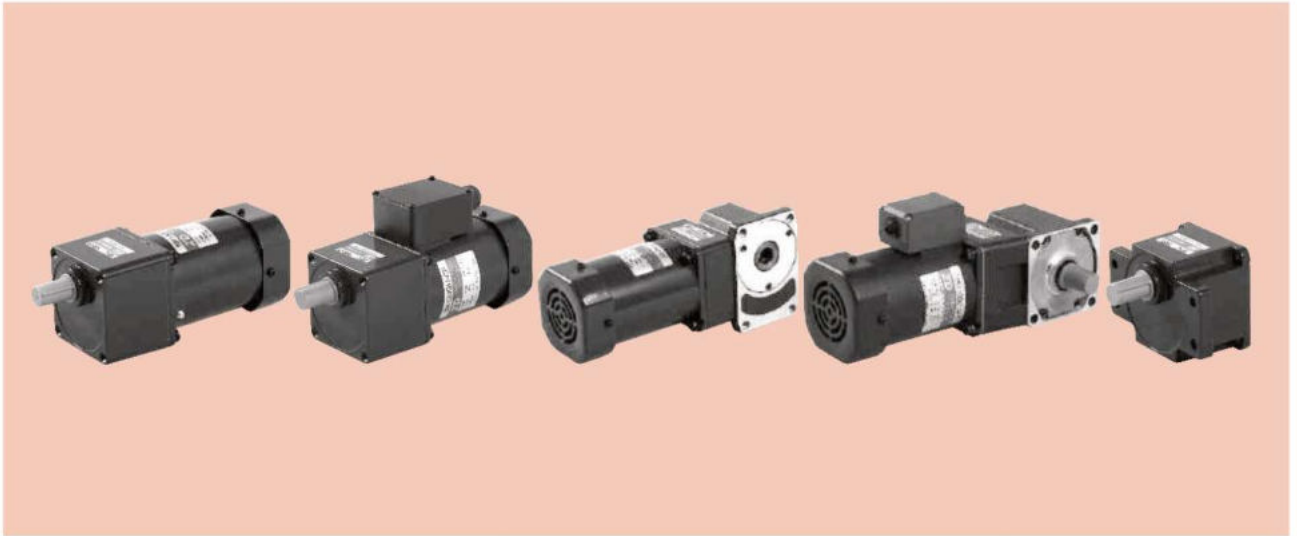

规格 Specs 连续额定 Continuous Rating

型号 Model · 类型 Type 上段:齿轮轴 Upper:Pinion Shaft 下段()内:圆轴 Below:Round Shaft		输出功率 Output power W	电压 Voltage V	频率 Frequency Hz	电流 Current A	启动转矩 Starting Torque mN.m	额定转矩 Rated Torque mN.m	额定转速 Rated Speed r/min	电容器容量 Capacitor μF
导线型 Lead Wire Type 外形图Dimensions①	带端子箱型 Terminal Box Type 外形图Dimensions②								
5IK120GU-AF (5IK120A-AF)	5IK120GU-AFT (5IK120A-AFT)	120	1ph 100	50	2.1	600	930	1250	30.0
				60	2.5		750	1550	
5IK120GU-EF (5IK120A-EF)	5IK120GU-EFT (5IK120A-EFT)	120	1ph 110	60	1.65	600	750	1550	25.0
			1ph 120		1.80				
5IK120GU-CF (5IK120A-CF)	5IK120GU-CFT (5IK120A-CFT)	120	1ph 220	50	1.0	650	930	1250	7.0
			1ph 230		0.95				
5IK120GU-HF (5IK120A-HF)	5IK120GU-HFT (5IK120A-HFT)	120	1ph 220	60	1.0	600	750	1550	-
			1ph 230		0.95				
5IK120GU-SF (5IK120A-SF)	5IK120GU-SFT (5IK120A-SFT)	120	3ph 220	50	0.70	1850	930	1250	-
				60	0.60	1600	750	1550	

- 各种安全规格以电动机铭牌上的型号名取得认证。
When the motor is approved under various safety standards, the model name on the nameplate is the approved model name.
- 注：“-A”型号中电压为110V时，配置电容器容量以实际铭牌为准。
Note:“-A” it means the voltage 110v,the assembly capacitor vaule it is according the labe.

种类 Type

● 电动机 Motor

机型 Type	型号 Model	
	齿轮轴型 Pinion Shaft	圆轴型 Round Shaft
导线型 Lead Wire Type	5IK120GU-AF	5IK120A-AF
	5IK120GU-EF	5IK120A-EF
	5IK120GU-CF	5IK120A-CF
	5IK120GU-HF	5IK120A-HF
	5IK120GU-SF	5IK120A-SF
带端子箱型 Terminal Box Type	5IK120GU-AFT	5IK120A-AFT
	5IK120GU-EFT	5IK120A-EFT
	5IK120GU-CFT	5IK120A-CFT
	5IK120GU-HFT	5IK120A-HFT
	5IK120GU-SFT	5IK120A-SFT

● 平行轴减速器（另售） Parallel Shaft Gearhead (Sold Separately)

减速器种类 Gearhead Type	减速器型号 Gearhead Model	减速比 Gear Ratio
长寿命●低噪音 Long Life ● Low Noise	5GU□KB	3、3.6、5、6、7.5、9、12.5、15、18、25、30、36、50、60、75、90、100、120、150、180、200
	5GU10XK (中间减速器 Decimal Gearhead)	

- 减速器型号的□中为减速比的数值
Enter the gear ratio in the box (□) within the model name

■ 装有减速器时的容许转矩 Gear Motor-Torque Table

- 减速器另售·中间减速器另售。电动机型号的□中为表示带端子箱型的记号(T)。
Gearhead and mid-gearbox can be sold separately. Enter the code that represents the terminal box type (T) in the box (□) within the model name.
- 减速品型号的□中为减速比的数值。
Enter the gear ratio in the box(□) within the model name.
- □色表示与电动机同一方向运转，其他则为相反方向。
The colored background □ indicates the same rotating direction of the motor while the rotating direction of others are opposite.
- 转速是以电动机的同步转速 (50Hz : 1500r/min、60Hz : 1800r/min) 为基准除以减速比而算出来的数值。实际转速将随负载大小变化所示数值减少2%~20%左右。
The speed is calculated by dividing the motor's synchronous speed(50Hz : 1500r/min、60Hz : 1800r/min) by the gear ratio. The actual speed is 2%~20% less than the displayed value, depending on the size of the load.
- 希望以大于下表的减速比进行进一步减速时，可在电动机与减速机之间安装减速比为10的中间减速机。这时的容许转矩为20N·m。
To reduce the speed beyond the gear ratio in the table, attach a decimal gearhead(gear ratio:10)between the gearhead and motor. In that case, the permissible torque is 20N·m.

■ 容许力矩单位 Allowance Torque Unit : 上段 Upside (N.m) /下段 Belowside (kgf.cm)

类型 Type 电动机/减速机 Motor/Gearhead	减速比 Gear Ratio	转速 Speed r/min	3	3.6	5	6	7.5	9	12.5	15	18	25	30	36	50	60	75	90	100	120	150	180	200	
			50Hz	500	417	300	250	200	166	120	100	83	60	50	41	30	25	20	16	15	12.5	10	8.3	7.5
5IK120GU-AF□ 5IK120GU-EF□ 5IK120GU-CF□ 5IK120GU-HF□ 5IK120GU-SF□	5GU□KB 5GU□K	50Hz	600	500	360	300	240	200	144	120	100	72	60	50	36	30	24	20	18	15	12	10	9	
			2.3	2.7	3.8	4.5	5.6	6.8	8.5	10.2	12.2	15.3	18.4	20	20	20	20	20	20	20	20	20	20	20
		60Hz	23.4	27.5	38.7	45.9	57.1	69.3	86.7	104	124	156	187	200	200	200	200	200	200	200	200	200	200	200
			1.8	2.2	3.0	3.6	4.6	5.5	6.8	8.2	9.8	12.4	14.9	17.8	20	20	20	18.8	20	20	20	20	20	20
			18.3	22.4	30.6	36.7	46.9	56.1	69.5	83.6	100	126	152	181	200	200	200	192	200	200	200	200	200	

■ 容许悬挂负载 · 容许轴向负载 To Allow The Hoisting Of The Load Allow Axial Load

电动机 (圆轴型) → 272页 Motor(Round Shaft) → P272
减速机 → 272页 Gearhead → P272

■ 减速机的容许负载惯性惯量 J Permissible Load Inertia J For Gearhead

→ 272页 → P272

■ 外形图 (单位 mm) Dimensions(Unit mm)

减速机附有安装用螺丝 Mounting screws are included with gearhead.

● 导线型 Lead Wiring Type ①

重量 Weight : 电动机 Motor : 3.4kg 减速器 Gearhead : 1.5kg

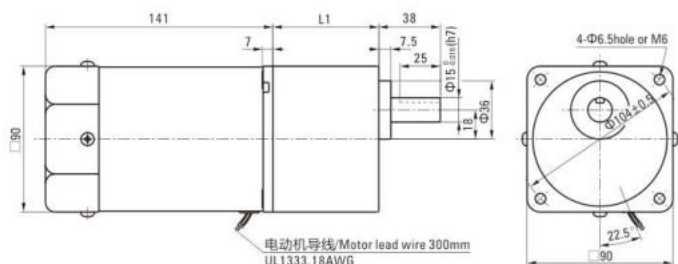

电动机型号 Motor Model	减速器型号 Gearhead Model	减速比 Gear Ratio	L1
5IK120GU-AF 5IK120GU-EF 5IK120GU-CF 5IK120GU-HF 5IK120GU-SF	5GU□KB	3~200	65.5

- 减速器型号的□中为减速比的数值
Enter the gear ratio in the box (□) within the model name

● 带端子箱型 Terminal Box Type ②

重量 Weight : 电动机 Motor : 3.55kg

减速器 Gearhead : 1.5kg

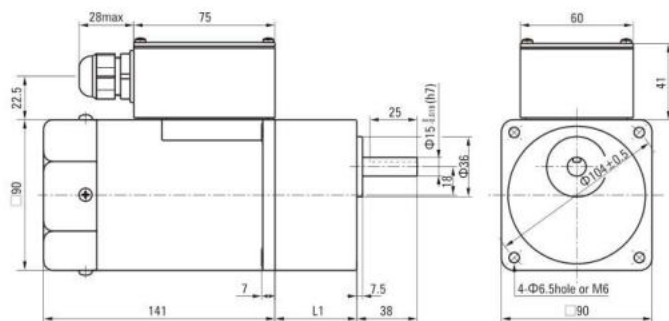

● 适用电缆直径为 Use cable with a diameter of $\Phi 6 \sim \Phi 12$ mm

电动机型号 Motor Model	减速器型号 Gearhead Model	减速比 Gear Ratio	L1
5IK120GU-AFT 5IK120GU-EFT 5IK120GU-CFT 5IK120GU-HFT 5IK120GU-SFT	5GU□KB	3~200	65.5

● 减速器型号的□中为减速比的数值
Enter the gear ratio in the box (□) within the model name

● 凸缘安装型减速器 Flange Mounting Reducer

可安装在GU齿轮轴型上

Can be mounted on GU type gear shaft

5GU□K

重量 Weight: 1.5kg

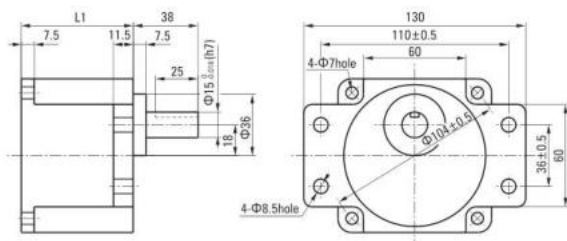

● 键·键槽 (减速器附件)

Key · Keyway (Accessory Of Gearhead)



● 圆轴型的转轴部分 Shaft Section Of Round Shaft Type

除重量及轴部外电动机外形与齿轮轴型相同。

Excluding weight and the shaft section motor shape are the same as those of the pinion shaft type.

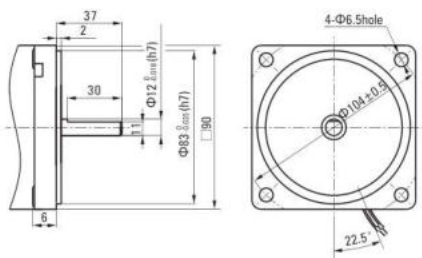

● 中间减速器 Decimal Gearhead

可安装在GU齿轮轴型上 Can be connected to GU pinion shaft type

电动机外形与齿轮轴型相同

5GU10XK

重量 Weight : 0.65kg

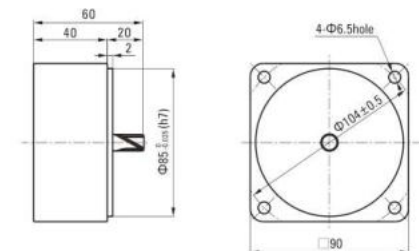

■ 电容器外形尺寸 Formal Dimension Of Capacitor

型号 Model		电容器型号 Capacitor Model	L	W	H
齿轮轴型 Pinion Shaft	圆轴型 Round Shaft				
5IK120GU-AF□	5IK120A-AF□	ZD300CAUL	58	26	38
5IK120GU-EF□	5IK120A-EF□	ZD250CAUL	47	27	37
5IK120GU-CF□	5IK120A-CF□	ZD70BFAUL	47	24	37

● 常规电容器出线为引线,也可根据客户要求配置插片式187#

Note: Conventional capacitor is a lead wire type. Inserted 187# is optional

● 电动机型号的□中为表示带端子箱型的记号(T)

Enter the code that represents the terminal box type (T) in the box (□) within the model name

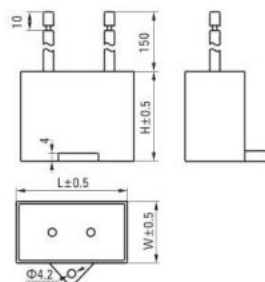

弧锥直角 SPIRAL BEVEL RIGHT ANGLE

■ 装有减速器时的容许转矩 Gear Motor-Torque Table

- 减速器 中间减速器另售。 • 电动机型号的□中为表示带端子箱型的记号(T)。
Gearhead and mid-gearbox can be sold separately. Enter the code that represents the terminal box type (T) in the box (□) within the model name.
- 减速器型号的□中为减速比的数值。 □ 色表示与电动机同一方向运转，其他则为相反方向。
Enter the gear ratio in the box (□) within the model name.
The colored background □ indicates the same rotating direction of the motor while the rotating direction of others are opposite.
- 转速是以电动机的同步转速 (50Hz:1500r/min、60Hz:1800r/min) 为基准除以减速比而算出来的数值。实际转速将随负载大小变化而比所示数值减少2%~20%左右。
The speed is calculated by diving the motor's synchronous speed (50Hz:1500r/min、60Hz:1800r/min) by the gear ratio. The actual speed is 2%~20% less than the displayed value, depending on the size of the load.
- 希望以大于下表的减速比进行进一步减速时，可在电动机与减速器之间安装减速比为10的中间减速器。这时的容许转矩为20N·m。
To reduce the speed beyond the gear ratio in the table, attach a mid-gearbox (gear ratio:10) between the gearhead and motor. In that case, the permissible torque is 20N·m.

■ 容许力矩单位 Allowance Torque Unit: 上段 Upside (N.m) / 下段 Belowside (kgf.cm)

机型Type 电动机/减速器 Motor/Gearhead	减速比Gear Ratio	容许力矩 Allowance Torque																			
		3	3.6	5	6	7.5	9	12.5	15	18	25	30	36	50	60	75	90	100	120	150	180
5IK120GU-AF□ 5IK120GU-EF□ 5IK120GU-CF□ 5IK120GU-HF□ 5IK120GU-SF□	50Hz	500	417	300	250	200	166	120	100	83	60	50	42	30	25	20	16	15	12	10	8
		600	500	360	300	240	200	144	120	100	72	60	50	36	30	24	20	18	15	12	10
5IK120GU-AF□ 5IK120GU-EF□ 5IK120GU-CF□ 5IK120GU-HF□ 5IK120GU-SF□	60Hz	500	417	300	250	200	166	120	100	83	60	50	42	30	25	20	16	15	12	10	8
		600	500	360	300	240	200	144	120	100	72	60	50	36	30	24	20	18	15	12	10

■ 感应尺寸图 Induction Type Drawing

5IK120GU-AF□/5GU□RC 5IK120GU-EF□/5GU□RC	5IK120GU-CF□/5GU□RC 5IK120GU-HF□/5GU□RC	5IK120GU-SF□/5GU□RC	5IK120GU-AF□/5GU□RT 5IK120GU-EF□/5GU□RT	5IK120GU-CF□/5GU□RT 5IK120GU-HF□/5GU□RT	5IK120GU-SF□/5GU□RT
--	--	---------------------	--	--	---------------------

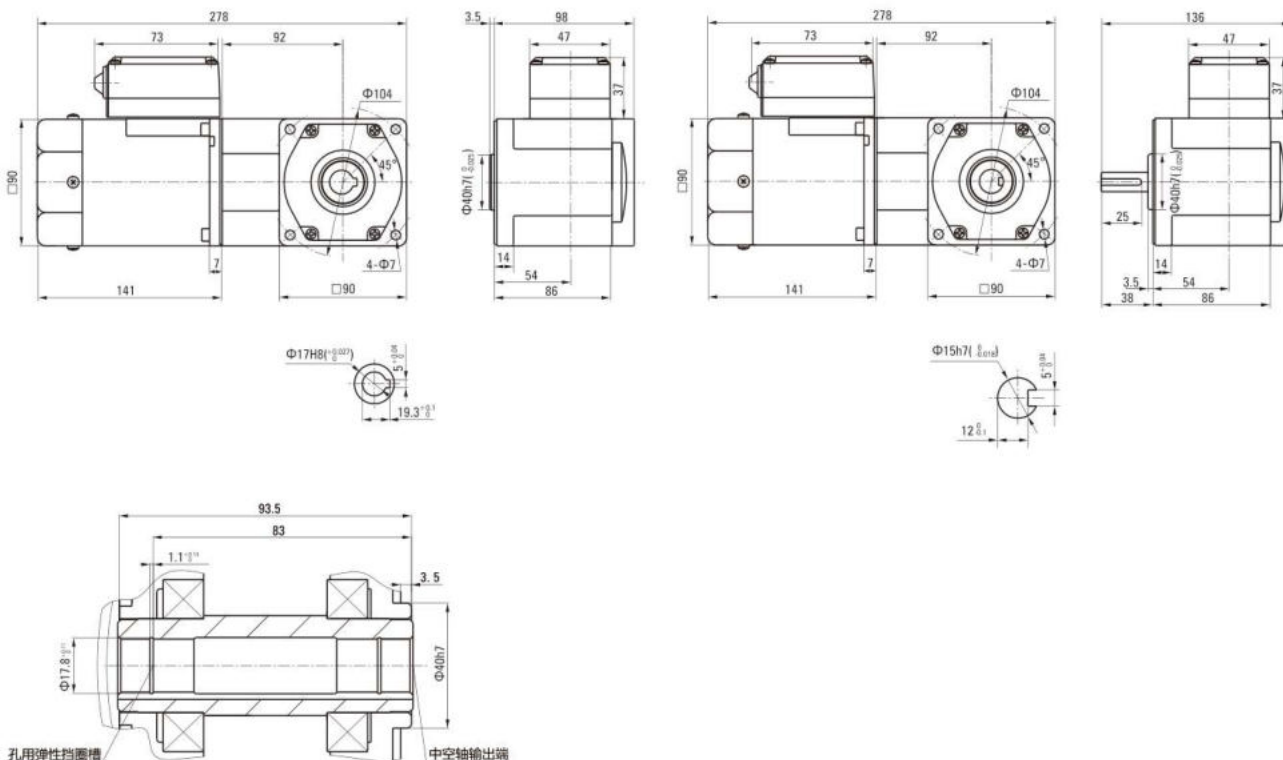

蜗轮蜗杆直角 WORM GEAR RIGHT ANGLE

■ 装有减速器时的容许转矩 Gear Motor-Torque Table

- 减速器-中间减速器另售。• 电动机型号的□中为表示带端子箱型的记号(T)。
Gearhead and mid-gearbox can be sold separately. Enter the code that represents the terminal box type (T) in the box (□) within the model name.
- 减速器型号的□中为减速比的数值。□色表示与电动机同一方向运转，其他则为相反方向。
Enter the gear ratio in the box (□) within the model name.
The colored background □ indicates the same rotating direction of the motor while the rotating direction of others are opposite.
- 转速是以电动机的同步转速 (50Hz:1500r/min、60Hz:1800r/min) 为基准除以减速比而算出来的数值。实际转速将随负载大小变化而比所示数值减少2%~20%左右。
The speed is calculated by dividing the motor's synchronous speed (50Hz:1500r/min、60Hz:1800r/min) by the gear ratio. The actual speed is 2%~20% less than the displayed value, depending on the size of the load.
- 希望以大于下表的减速比进行进一步减速时，可在电动机与减速器之间安装减速比为10的中间减速器。这时的容许转矩为20N·m。
To reduce the speed beyond the gear ratio in the table, attach a mid-gearbox (gear ratio:10) between the gearhead and motor. In that case, the permissible torque is 20N·m.

■ 容许力矩单位 Allowance Torque Unit: 上段 Upside (N.m) / 下段 Belowside (kgf.cm)

机型Type	减速比Gear Ratio	3	3.6	5	6	7.5	9	12.5	15	18	25	30	36	50	60	75	90	100	120	150	180			
电动机/减速器 Motor/Gearhead	转速Speed r/min	50Hz	500	417	300	250	200	166	120	100	83	60	50	42	30	25	20	16	15	12	10	8		
	60Hz	600	500	360	300	240	200	144	120	100	72	60	50	36	30	24	20	18	15	12	10	10		
5IK120GU-AF□ 5IK120GU-EF□ 5IK120GU-CF□ 5IK120GU-HF□ 5IK120GU-SF□	容许力矩 Allowance Torque	50Hz	5GU□RH	1.24	1.49	1.86	2.23	2.78	3.34	4.64	5.57	6.68	9.28	11.1	13.4	18.6	20.0	20.0	20.0	20.0	20.0	20.0	20.0	
			5GU□RA	12.6	15.2	18.9	22.7	28.4	34.1	47.4	56.8	68.2	94.7	114	136	189	200	200	200	200	200	200	200	200
		60Hz	1.00	1.20	1.50	1.80	2.25	2.69	3.74	4.49	5.39	7.49	8.98	10.8	15.0	18.0	20.0	20.0	20.0	20.0	20.0	20.0	20.0	20.0
			10.18	12.2	15.3	18.3	22.9	27.5	38.2	45.8	55.0	76.4	91.7	110	153	183	200	200	200	200	200	200	200	200

■ 感应尺寸图 Induction Type Drawing

5IK120GU-AF□/5GU□RH 5IK120GU-EF□/5GU□RH	5IK120GU-CF□/5GU□RH 5IK120GU-HF□/5GU□RH	5IK120GU-SF□/5GU□RH	5IK120GU-AF□/5GU□RA 5IK120GU-EF□/5GU□RA	5IK120GU-CF□/5GU□RA 5IK120GU-HF□/5GU□RA	5IK120GU-SF□/5GU□RA
--	--	---------------------	--	--	---------------------

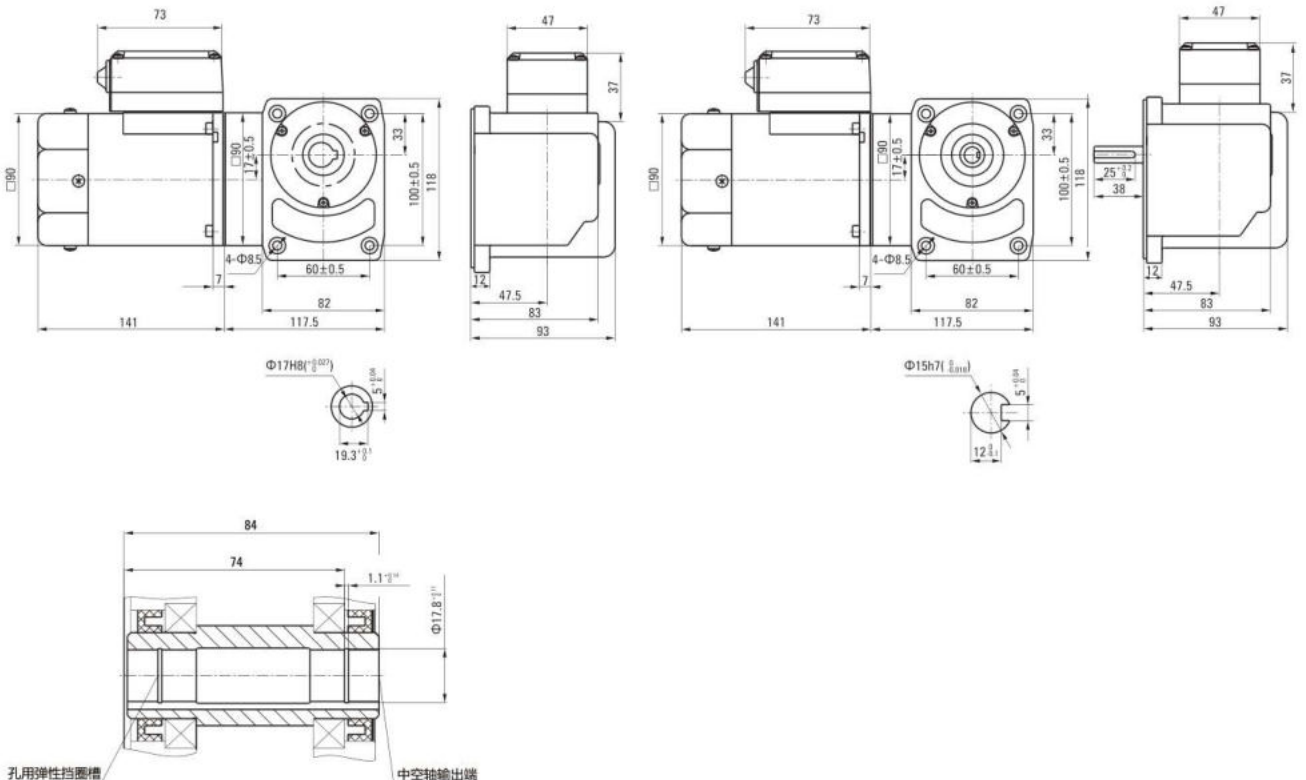

连接图 Wiring Diagram

●运转方向指从电动机轴看来的方向。CW表示顺时针方向，CCW表示逆时针方向。

The direction of motor rotation is as viewed from the shaft end of motor. CW represents the clockwise direction, while CCW represents the counterclockwise direction.

●表中所记品名为齿轮轴型，圆轴型亦同。

Name indicated in the list is pinion shaft type, also valid for the equivalent round shaft type.

导线型 Lead Wire Type		
5IK120GU-AF、5IK120GU-EF、5IK120GU-HF、5IK120GU-CF		5IK120GU-SF
<p>顺时针方向CW</p> <p>电容器 Capacitance</p>	<p>逆时针方向CCW</p> <p>电容器 Capacitance</p>	<p>顺时针方向CW</p> <p>逆时针方向CCW 若对换R、S、T中任意二条，电动机会作逆时针方向运转 To change the rotation direction change any two connections among R, S and T</p>
带端子箱型 Terminal Box Type		
5IK120GU-AFT、5IK120GU-EFT、5IK120GU-HFT、5IK120GU-CFT		5IK120GU-SFT
<p>顺时针方向CW</p> <p>电容器 Capacitance</p>	<p>逆时针方向CCW</p> <p>电容器 Capacitance</p>	<p>顺时针方向CW</p> <p>逆时针方向CCW 若对换U、V、W中任意二条，电动机会作逆时针方向运转 To change the rotation direction change any two connections among U, V and W</p>

请注意 Note:

单相电动机运转方向的转换应在电动机停止后进行。

Change the direction of single-phase motor rotation only after bring the motor to a stop.

若在电动机运转时转换运转方向，可能发生无法转换运转方向或须费时较久的情况。

If an attempt is made to change the direction of rotation while the motor is rotating, motor may ignore reversing command or change its direction of rotation after some delay.

感应电动机 INDUCTION MOTORS

■ 120W □ 104mm



规格 Specs 连续额定 Continuous Rating

型号 Model · 类型 Type 上段:齿轮轴 Upper:Pinion Shaft 下段()内:圆轴 Below:Round Shaft		输出功率 Output power W	电压 Voltage V	频率 Frequency Hz	电流 Current A	启动转矩 Starting Torque mN.m	额定转矩 Rated Torque mN.m	额定转速 Rated Speed r/min	电容器容量 Capacitor μF
导线型 Lead Wire Type 外形图Dimensions①	带端子箱型 Terminal Box Type 外形图Dimensions②								
6IK120GU-AF (6IK120A-AF)	6IK120GU-AFT (6IK120A-AFT)	120	1ph 100	50	2.10	600	930	1250	30.0
				60	2.50		750	1550	
6IK120GU-EF (6IK120A-EF)	6IK120GU-EFT (6IK120A-EFT)	120	1ph 110	60	1.70	600	750	1550	20.0
			1ph 120		1.80				
6IK120GU-CF (6IK120A-CF)	6IK120GU-CFT (6IK120A-CFT)	120	1ph 220	50	0.95	750	930	1250	8.0
			1ph 230						
6IK120GU-HF (6IK120A-HF)	6IK120GU-HFT (6IK120A-HFT)	120	1ph 220	60	0.95	700	750	1550	
			1ph 230		1.00				
6IK120GU-SF (6IK120A-SF)	6IK120GU-SFT (6IK120A-SFT)	120	3ph 220	50	0.75	2200	890	1300	
				60	0.70	2000	730	1600	

- 各种安全规格以电动机铭牌上的型号名取得认证。
When the motor is approved under various safety standards, the model name on the nameplate is the approved model name.
- 注：“-A”型号中电压为110V时，配置电容器容量以实际铭牌为准。
Note:“-A” it means the voltage 110v,the assembly capacitor vaule it is according the labe.

种类 Type

● 电动机 Motor

机型 Type	型号 Model	
	齿轮轴型 Pinion Shaft	圆轴型 Round Shaft
导线型 Lead Wire Type	6IK120GU-AF	6IK120A-AF
	6IK120GU-EF	6IK120A-EF
	6IK120GU-CF	6IK120A-CF
	6IK120GU-HF	6IK120A-HF
	6IK120GU-SF	6IK120A-SF
带端子箱型 Terminal Box Type	6IK120GU-AFT	6IK120A-AFT
	6IK120GU-EFT	6IK120A-EFT
	6IK120GU-CFT	6IK120A-CFT
	6IK120GU-HFT	6IK120A-HFT
	6IK120GU-SFT	6IK120A-SFT

● 平行轴减速器（另售） Parallel Shaft Gearhead (Sold Separately)

减速器种类 Gearhead Type	减速器型号 Gearhead Model	减速比 Gear Ratio
长寿命●低噪音 Long Life ● Low Noise	6GU□K	3、3.6、5、6、7.5、9、12.5、15、18、25、30、36、50、60、75、90、100、120、150、180、200

- 减速器型号的□中为减速比的数值
Enter the gear ratio in the box (□) within the model name

■ 装有减速器时的容许转矩 Gear Motor-Torque Table

- 减速器另售·中间减速器另售。电动机型号的□中为表示带端子箱型的记号(T)。
Gearhead and mid-gearbox can be sold separately. Enter the code that represents the terminal box type (T) in the box (□) within the model name.
- 减速品型号的□中为减速比的数值。
Enter the gear ratio in the box(□) within the model name.
- □色表示与电动机同一方向运转，其他则为相反方向。
The colored background □ indicates the same rotating direction of the motor while the rotating direction of others are opposite.
- 转速是以电动机的同步转速 (50Hz : 1500r/min、60Hz : 1800r/min) 为基准除以减速比而算出来的数值。实际转速将随负载大小变化所示数值减少2%~20%左右。
The speed is calculated by dividing the motor's synchronous speed(50Hz : 1500r/min、60Hz : 1800r/min) by the gear ratio. The actual speed is 2%~20% less than the displayed value, depending on the size of the load.
- 希望以大于下表的减速比进行进一步减速时，可在电动机与减速机之间安装减速比为10的中间减速机。这时的容许转矩为20N·m。
To reduce the speed beyond the gear ratio in the table, attach a decimal gearhead(gear ratio:10)between the gearhead and motor. In that case, the permissible torque is 20N·m.

■ 容许力矩单位 Allowance Torque Unit : 上段 Upside (N.m) /下段 Belowside (kgf.cm)

类型 Type 电动机/减速机 Motor/Gearhead	减速比 Gear Ratio		3	3.6	5	6	7.5	9	12.5	15	18	25	30	36	50	60	75	90	100	120	150	180	200		
	转速 Speed r/min	50Hz	500	417	300	250	200	166	120	100	83	60	50	41	30	25	20	16	15	12.5	10	8.3	7.5		
6IK120GU-AF□ 6IK120GU-EF□ 6IK120GU-SF□	6GU□K	50Hz	2.3	2.7	3.8	4.5	5.6	6.8	8.5	10.2	12.2	15.3	18.4	22.1	30.7	36.8	40	40	40	40	40	40	40	40	
			23.4	27.5	38.7	45.9	57.1	69.3	86.7	104	124	156	187	225	313	375	400	400	400	400	400	400	400	400	400
			2.22	2.6	3.6	4.3	5.4	6.5	8.1	9.7	11.7	14.7	17.6	21.1	29.4	35.2	40	40	40	40	40	40	40	40	40
			2.4	26.5	36.7	43.8	55.0	66.3	87.6	98.8	119	149	179	21.5	300	359	400	400	400	400	400	400	400	400	400

■ 容许力矩单位 Allowance Torque Unit : 上段 Upside (N.m) /下段 Belowside (kgf.cm)

类型 Type 电动机/减速机 Motor/Gearhead	减速比 Gear Ratio		3	3.6	5	6	7.5	9	12.5	15	18	25	30	36	50	60	75	90	100	120	150	180	200		
	转速 Speed r/min	60Hz	600	500	360	300	240	200	144	120	100	72	60	50	36	30	24	20	18	15	12	10			
6IK120GU-AF□ 6IK120GU-EF□ 6IK120GU-HF□ 6IK120GU-SF□	6GU□K	60Hz	1.8	2.2	3.0	3.6	4.6	5.5	6.8	8.2	9.8	12.4	14.9	17.8	24.8	29.7	37.1	40	40	40	40	40	40	40	
			18.3	22.4	30.6	36.7	46.9	56.1	69.3	83.6	100	126	152	181	253	303	378	400	400	400	400	400	400	400	400
			1.8	2.2	3.0	3.6	4.4	5.3	6.7	8.0	9.6	12.0	14.5	17.3	24.1	28.9	36.1	40	40	40	40	40	40	40	40
			18.3	22.4	30.6	36.7	44.8	54.0	68.3	81.6	97.9	122	148	176	245	295	368	400	400	400	400	400	400	400	400

■ 容许悬挂负载 · 容许轴向负载 To Allow The Hoisting Of The Load Allow Axial Load

电动机 (圆轴型) → 272页 Motor(Round Shaft) → P272
减速机 → 272页 Gearhead → P272

■ 减速机的容许负载惯性惯量 J Permissible Load Inertia J For Gearhead

→ 272页 → P272

外形图 (单位 mm) Dimensions(Unit mm)

减速器附有安装用螺丝 Mounting screws are included with gearhead.

● 导线型 Lead wiring Type ①

重量 Weight : 电动机 Motor : 4.8kg 减速器 Gearhead : 2.1kg

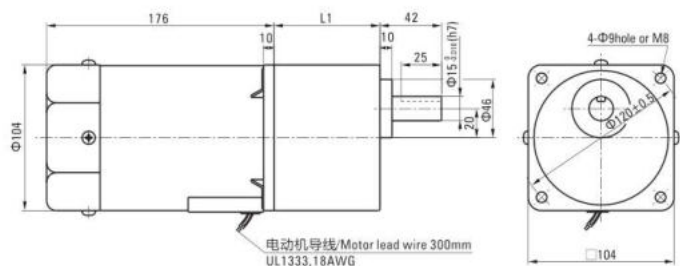

电动机型号 Motor Model	减速器型号 Gearhead Model	减速比 Gear Ratio	L1
6IK120GU-AF 6IK120GU-EF 6IK120GU-CF 6IK120GU-HF 6IK120GU-SF	6GU□K	3~200	72

● 减速器型号的□中为减速比的数值
Enter the gear ratio in the box (□) within the model name

● 带端子箱型 Terminal Box Type ②

重量 Weight : 电动机 Motor : 4.95kg 减速器 Gearhead : 2.1kg

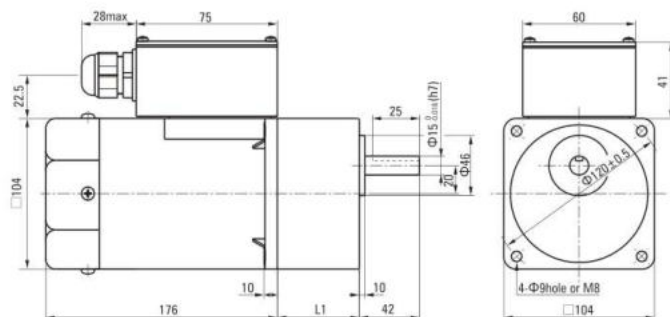

电动机型号 Motor Model	减速器型号 Gearhead Model	减速比 Gear Ratio	L1
6IK120GU-AFT 6IK120GU-EFT 6IK120GU-CFT 6IK120GU-HFT 6IK120GU-SFT	6GU□K	3~200	72

● 减速器型号的□中为减速比的数值
Enter the gear ratio in the box (□) within the model name

● 适用电缆直径为 Use cable with a diameter of $\Phi 6 \sim \Phi 12$ mm

● 圆轴型的转轴部分 Shaft Section Of Round Shaft Type

除重量及轴部外电动机外形与齿轮轴型相同。
Excluding weight and the shaft section motor shape are the same as those of the pinion shaft type.

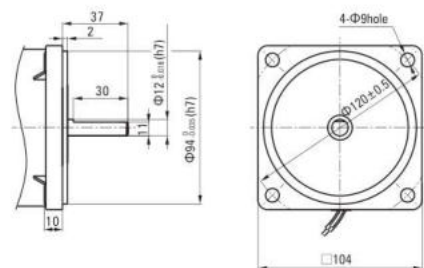

● 键·键槽 (减速器附件)

Key · Keyway (Accessory Of Gearhead)

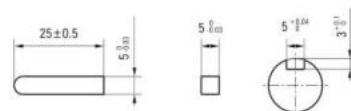

电容器外形尺寸 Formal Dimension Of Capacitor

型号 Model		电容器型号 Capacitor Model	L	W	H
齿轮轴型 Pinion Shaft	圆轴型 Round Shaft				
6IK120GU-AF	6IK120A-AF	ZD300CAUL	58	26	38
6IK120GU-EF	6IK120A-EF	ZD200CAUL	47	23	35
6IK120GU-CF	6IK120A-CF	ZD80BFAUL	48	26.5	38

● 常规电容器出线为引线,也可根据客户要求配置插片式187#

Note: Conventional capacitor is a lead wire type. Inserted 187# is optional

● 电动机型号的□中为表示带端子箱型的记号(T)

Enter the code that represents the terminal box type (T) in the box (□) within the model name

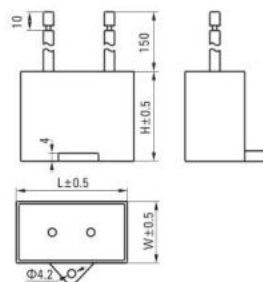

弧锥直角 SPIRAL BEVEL RIGHT ANGLE

■ 装有减速器时的容许转矩 Gear Motor-Torque Table

- 减速器-中间减速器另售。• 电动机型号的□中为表示带端子箱型的记号(T)。
Gearhead and mid-gearbox can be sold separately. Enter the code that represents the terminal box type (T) in the box (□) within the model name.
- 减速器型号的□中为减速比的数值。□色表示与电动机同一方向运转，其他则为相反方向。
Enter the gear ratio in the box (□) within the model name.
The colored background □ indicates the same rotating direction of the motor while the rotating direction of others are opposite.
- 转速是以电动机的同步转速 (50Hz:1500r/min、60Hz:1800r/min) 为基准除以减速比而算出来的数值。实际转速将随负载大小变化而比所示数值减少2%~20%左右。
The speed is calculated by diving the motor's synchronous speed (50Hz:1500r/min、60Hz:1800r/min) by the gear ratio. The actual speed is 2%~20% less than the displayed value, depending on the size of the load.
- 希望以大于下表的减速比进行进一步减速时，这时的容许转矩为60N·m。
To reduce the speed beyond the gear ratio in the table, In that case, the permissible torque is 60N·m.

■ 容许力矩单位 Allowance Torque Unit: 上段 Upside (N.m) / 下段 Belowside (kgf.cm)

机型Type 电动机/减速器 Motor/Gearhead	减速比Gear Ratio	转速Speed r/min	3	3.6	5	6	7.5	9	12.5	15	18	25	30	36	50	60	75	90	100	120	150	180
			6IK120GU-AF□ 6IK120GU-EF□ 6IK120GU-CF□ 6IK120GU-HF□ 6IK120GU-SF□	容许力矩 Allowance Torque	50Hz	1.70	2.05	2.84	3.41	4.26	5.68	7.89	9.47	11.4	15.8	18.9	22.7	28.4	34.1	42.6	51.1	56.8
		60Hz	1.37	1.65	2.29	2.75	3.44	4.58	6.36	7.64	9.16	12.7	15.3	18.3	22.9	27.5	34.4	41.2	45.8	55.0	60.0	60.0

■ 感应、可逆尺寸图 Induction, Reversible Type Drawing

6IK120GU-AF□/6GU□RC 6IK120GU-EF□/6GU□RC	6IK120GU-CF□/6GU□RC 6IK120GU-HF□/6GU□RC	6IK120GU-SF□/6GU□RC	6IK120GU-AF□/6GU□RT 6IK120GU-EF□/6GU□RT	6IK120GU-CF□/6GU□RT 6IK120GU-HF□/6GU□RT	5IK120GU-SF□/6GU□RT
--	--	---------------------	--	--	---------------------

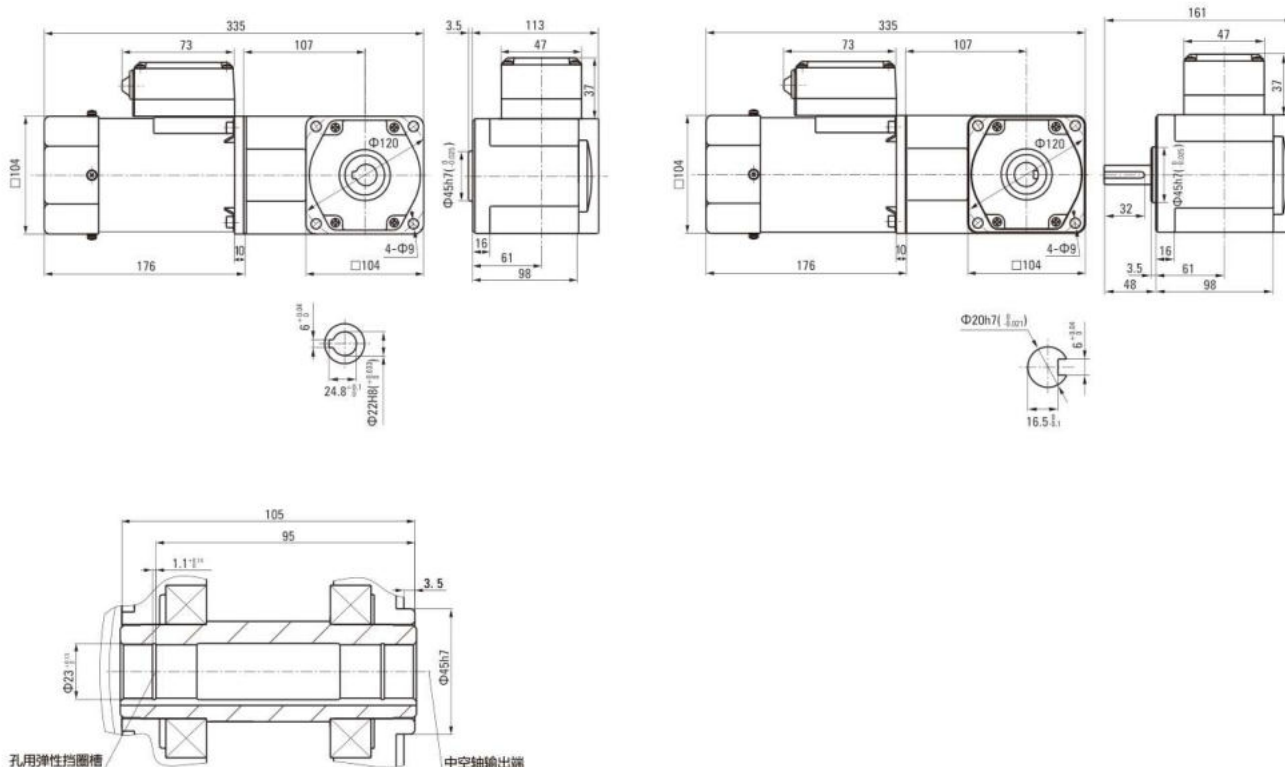

■ 连接图 Wiring Diagram

- 运转方向指从电动机轴看来的方向。CW表示顺时针方向，CCW表示逆时针方向。

The direction of motor rotation is as viewed from the shaft end of motor. CW represents the clockwise direction, while CCW represents the counterclockwise direction.

- 表中所记品名为齿轮轴型，圆轴型亦同。

Name indicated in the list is pinion shaft type, also valid for the equivalent round shaft type.

导线型 Lead Wire Type		
6IK120GU-AF、6IK120GU-EF、6IK120GU-HF、6IK120GU-CF		6IK120GU-SF
顺时针方向CW 	逆时针方向CCW 	顺时针方向CW 逆时针方向CCW 若对换R、S、T中任意二条，电动机会作逆时针方向运转 To change the rotation direction change any two connections among R, S and T
带端子箱型 Terminal Box Type		
6IK120GU-AFT、6IK120GU-EFT、6IK120GU-HFT、6IK120GU-CFT		6IK120GU-SFT
顺时针方向CW 	逆时针方向CCW 	顺时针方向CW 逆时针方向CCW 若对换U、V、W中任意二条，电动机会作逆时针方向运转 To change the rotation direction change any two connections among U, V and W

请注意 Note:

单相电动机运转方向的转换应在电动机停止后进行。

Change the direction of single-phase motor rotation only after bring the motor to a stop.

若在电动机运转时转换运转方向，可能发生无法转换运转方向或须费时较久的情况。

If an attempt is made to change the direction of rotation while the motor is rotating, motor may ignore reversing command or change its direction of rotation after some delay.

感应电动机 INDUCTION MOTORS

■ 140W □ 104mm

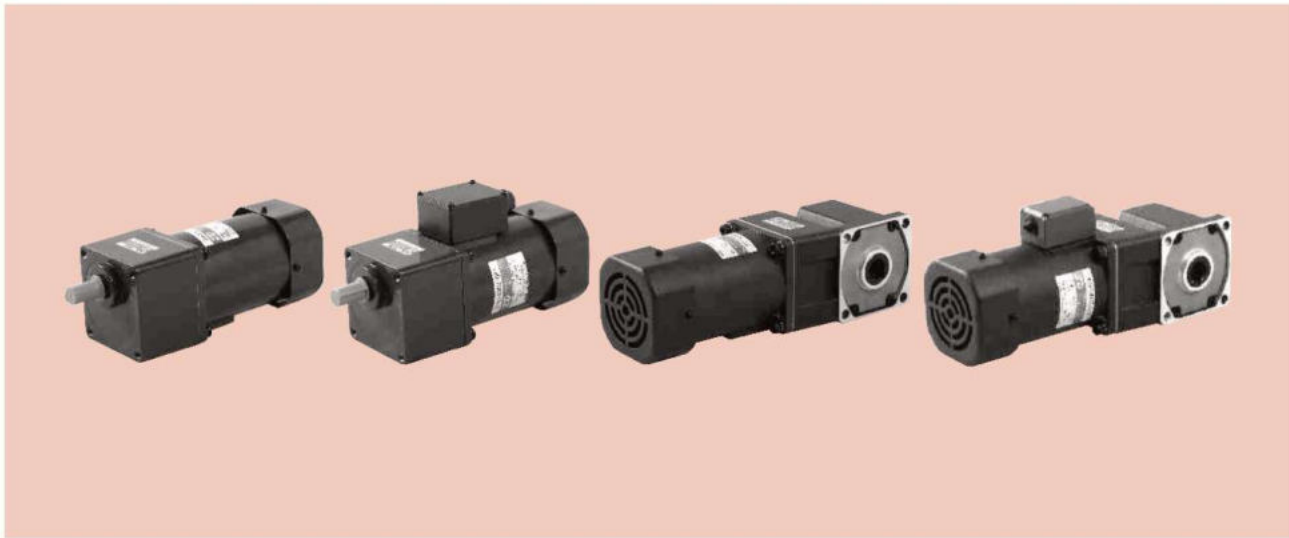

规格 Specs 连续额定 Continuous Rating

型号Model · 类型 Type		输出功率 Output power W	电压 Voltage V	频率 Frequency Hz	电流 Current A	启动转矩 Starting Torque mN.m	额定转矩 Rated Torque mN.m	额定转速 Rated Speed r/min	电容器容量 Capacitor μF
上段:齿轮轴 Upper:Pinion Shaft 下段()内:圆轴 Below:Round Shaft	带端子箱型 Terminal Box Type 外形图Dimensions②								
导线型 Lead Wire Type 外形图Dimensions①	带端子箱型 Terminal Box Type 外形图Dimensions②								
6IK140GU-AF (6IK140A-AF)	6IK140GU-AFT (6IK140A-AFT)	140	1ph 100	50	2.7	700	1080	1250	35.0
				60	3.0		870	1550	
6IK140GU-EF (6IK140A-EF)	6IK140GU-EFT (6IK140A-EFT)	140	1ph 110	60	1.80	700	850	1600	25.0
			1ph 120		1.95				
6IK140GU-CF (6IK140A-CF)	6IK140GU-CFT (6IK140A-CFT)	140	1ph 220	50	1.05	850	1040	1350	10.0
			1ph 230		1.15				
6IK140GU-HF (6IK140A-HF)	6IK140GU-HFT (6IK140A-HFT)	140	1ph 220	60	1.05	750	850	1600	
			1ph 230		1.15				
6IK140GU-SF (6IK140A-SF)	6IK140GU-SFT (6IK140A-SFT)	140	3ph 220	50	0.85	2700	1080	1250	
				60	0.75				

●各种安全规格以电动机铭牌上的型号名取得认证。

When the motor is approved under various safety standards, the model name on the nameplate is the approved model name.

●注：“-A”型号中电压为110V时，配置电容器容量以实际铭牌为准。

Note:“-A” it means the voltage 110v,the assembly capacitor vaule it is according the label.

种类 Type

● 电动机 Motor

机型 Type	型号Model	
	齿轮轴型 Pinion Shaft	圆轴型 Round Shaft
导线型 Lead Wire Type	6IK140GU-AF	6IK140A-AF
	6IK140GU-EF	6IK140A-EF
	6IK140GU-CF	6IK140A-CF
	6IK140GU-HF	6IK140A-HF
	6IK140GU-SF	6IK140A-SF
带端子箱型 Terminal Box Type	6IK140GU-AFT	6IK140A-AFT
	6IK140GU-EFT	6IK140A-EFT
	6IK140GU-CFT	6IK140A-CFT
	6IK140GU-HFT	6IK140A-HFT
	6IK140GU-SFT	6IK140A-SFT

● 平行轴减速器 (另售) Parallel Shaft Gearhead (Sold Separately)

减速器种类 Gearhead Type	减速器型号 Gearhead Model	减速比 Gear Ratio
长寿命●低噪音 Long Life ● Low Noise	6GU□K	3、3.6、5、6、7.5、9、 12.5、15、18、25、30、 36、50、60、75、90、 100、120、150、180、200

●减速器型号的□中为减速比的数值

Enter the gear ratio in the box (□) within the model name

■ 装有减速器时的容许转矩 Gear Motor-Torque Table

- 减速器另售·中间减速器另售。电动机型号的□中为表示带端子箱型的记号(T)。
Gearhead and mid-gearbox can be sold separately. Enter the code that represents the terminal box type (T) in the box (□) within the model name.
- 减速品型号的□中为减速比的数值。
Enter the gear ratio in the box(□) within the model name.
- □色表示与电动机同一方向运转，其他则为相反方向。
The colored background □ indicates the same rotating direction of the motor while the rotating direction of others are opposite.
- 转速是以电动机的同步转速（50Hz：1500r/min、60Hz：1800r/min）为基准除以减速比而算出来的数值。实际转速将随负载大小变化所示数值减少2%~20%左右。
The speed is calculated by dividing the motor's synchronous speed(50Hz：1500r/min、60Hz：1800r/min) by the gear ratio. The actual speed is 2%~20% less than the displayed value, depending on the size of the load.
- 希望以大于下表的减速比进行进一步减速时，可在电动机与减速机之间安装减速比为10的中间减速机。这时的容许转矩为20N·m。
To reduce the speed beyond the gear ratio in the table, attach a decimal gearhead(gear ratio:10)between the gearhead and motor. In that case, the permissible torque is 20N·m.

■ 容许力矩单位 Allowance Torque Unit：上段 Upside (N.m) /下段 Belowside (kgf.cm)

类型 Type 电动机/减速机 Motor/Gearhead	减速比 Gear Ratio		3	3.6	5	6	7.5	9	12.5	15	18	25	30	36	50	60	75	90	100	120	150	180	200	
	转速 Speed r/min	50Hz	500	417	300	250	200	166	120	100	83	60	50	41	30	25	20	16	15	12.5	10	8.3	7.5	
6IK140GU-AF□ 6IK140GU-EF□ 6IK140GU-SF□	6GU□K	50Hz	2.6	3.1	4.4	5.2	6.6	7.9	9.9	11.8	14.2	17.8	21.4	25.7	35.6	40	40	40	40	40	40	40	40	40
			26.5	31.6	44.8	53.0	67.3	80.6	101	120	144	181	218	262	363	400	400	400	400	400	400	400	400	400
			2.5	3.0	4.2	5.1	6.3	7.6	9.5	11.4	13.7	17.2	20.6	247	34.3	40	40	40	40	40	40	40	40	40
			25.5	30.6	42.8	52.0	63.2	77.5	96.9	116	139	175	210	252	349	400	400	400	400	400	400	400	400	400

■ 容许力矩单位 Allowance Torque Unit：上段 Upside (N.m) /下段 Belowside (kgf.cm)

类型 Type 电动机/减速机 Motor/Gearhead	减速比 Gear Ratio		3	3.6	5	6	7.5	9	12.5	15	18	25	30	36	50	60	75	90	100	120	150	180	200	
	转速 Speed r/min	60Hz	600	500	360	300	240	200	144	120	100	72	60	50	36	30	24	20	18	15	12	10	9	
6IK140GU-AF□ 6IK140GU-SF□ 6IK140GU-EF□ 6IK140GU-HF□	6GU□K	60Hz	2.1	2.5	3.5	4.2	5.3	6.3	7.9	9.5	11.4	14.4	17.2	20.7	28.7	34.5	40	40	40	40	40	40	40	
			21.4	25.5	35.7	42.8	54.0	64.2	80.6	96.9	116	147	175	211	292	352	400	400	400	400	400	400	400	
			2.1	2.5	3.4	4.1	5.2	6.2	7.8	9.3	11.2	12.0	16.8	20.2	28.0	33.7	40	40	40	40	40	40	40	40
			21.4	25.5	34.6	41.8	53.0	63.2	79.5	94.8	114	122	171	206	285	343	400	400	400	400	400	400	400	400

■ 容许悬挂负载·容许轴向负载 To Allow The Hoisting Of The Load Allow Axial Load

电动机(圆轴型)→P272页 Motor(Round Shaft)→P272
减速机→272页 Gearhead→P272

■ 减速机的容许负载惯性惯量 J Permissible Load Inertia J For Gearhead

→272页→P272

外形图 (单位 mm) Dimensions(Unit mm)

减速器附有安装用螺丝 Mounting screws are included with gearhead.

● 导线型 Lead Wiring Type ①

重量 Weight : 电动机 Motor : 5.0kg 减速器 Gearhead : 2.1kg

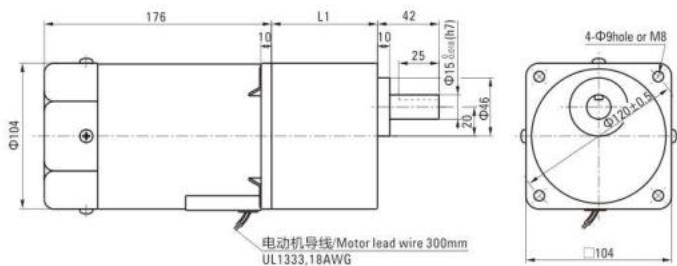

电动机型号 Motor Model	减速器型号 Gearhead Model	减速比 Gear Ratio	L1
6IK140GU-AF 6IK140GU-EF 6IK140GU-CF 6IK140GU-HF 6IK140GU-SF	6GU□K	3~200	72

● 减速器型号的□中为减速比的数值
Enter the gear ratio in the box (□) within the model name

● 带端子箱型 Terminal Box Type ②

重量 Weight : 电动机 Motor : 5.15kg 减速器 Gearhead : 2.1kg

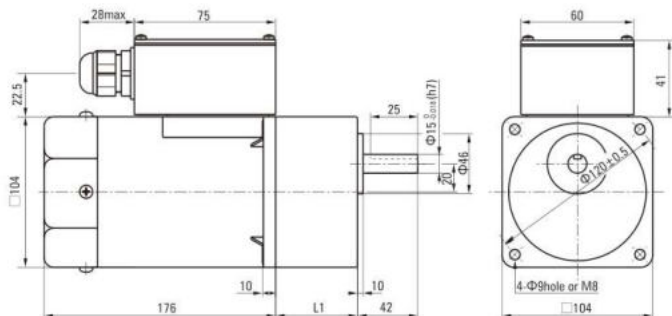

电动机型号 Motor Model	减速器型号 Gearhead Model	减速比 Gear Ratio	L1
6IK140GU-AFT 6IK140GU-EFT 6IK140GU-CFT 6IK140GU-HFT 6IK140GU-SFT	6GU□K	3~200	72

● 减速器型号的□中为减速比的数值
Enter the gear ratio in the box (□) within the model name

● 适用电缆直径为 Use cable with a diameter of $\Phi 6 \sim \Phi 12$ mm

● 圆轴型的转轴部分 Shaft Section Of Round Shaft Type

除重量及轴部外电动机外形与齿轮轴型相同。
Excluding weight and the shaft section motor shape are the same as those of the pinion shaft type.

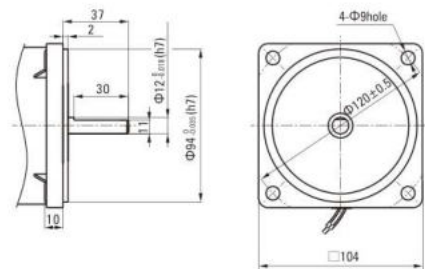

● 键·键槽 (减速器附件)

Key · Keyway (Accessory Of Gearhead)

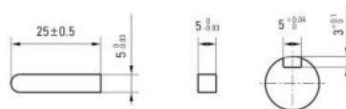

电容器外形尺寸 Formal Dimension Of Capacitor

型号 Model		电容器型号 Capacitor Model	L	W	H
齿轮轴型 Pinion Shaft	圆轴型 Round Shaft				
6IK140GU-AF	6IK140A-AF	ZD350CFAUL	58	30	40
6IK140GU-EF	6IK140A-EF	ZD250CFAUL	47	27	37
6IK140GU-CF	6IK140A-CF	ZD100BFAUL	58	26	38

● 常规电容器出线为引线,也可根据客户要求配置插片式187#

Note: Conventional capacitor is a lead wire type. Inserted 187# is optional

● 电动机型号的□中为表示带端子箱型的记号(T)

Enter the code that represents the terminal box type (T) in the box (□) within the model name

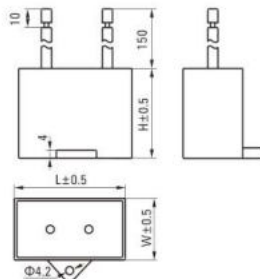

弧锥直角 SPIRAL BEVEL RIGHT ANGLE

■ 装有减速器时的容许转矩 Gear Motor-Torque Table

- 减速器-中间减速器另售。• 电动机型号的□中为表示带端子箱型的记号(T)。
Gearhead and mid-gearbox can be sold separately. Enter the code that represents the terminal box type (T) in the box (□) within the model name.
- 减速器型号的□中为减速比的数值。□色表示与电动机同一方向运转，其他则为相反方向。
Enter the gear ratio in the box (□) within the model name.
The colored background □ indicates the same rotating direction of the motor while the rotating direction of others are opposite.
- 转速是以电动机的同步转速 (50Hz:1500r/min、60Hz:1800r/min) 为基准除以减速比而算出来的数值。实际转速将随负载大小变化而比所示数值减少2%~20%左右。
The speed is calculated by dividing the motor's synchronous speed (50Hz:1500r/min、60Hz:1800r/min) by the gear ratio. The actual speed is 2%~20% less than the displayed value, depending on the size of the load.
- 希望以大于下表的减速比进行进一步减速时，这时的容许转矩为60N·m。
To reduce the speed beyond the gear ratio in the table, In that case, the permissible torque is 60N·m.

■ 容许力矩单位 Allowance Torque Unit: 上段 Upside (N.m) / 下段 Belowside (kgf.cm)

机型Type	减速比Gear Ratio	3	3.6	5	6	7.5	9	12.5	15	18	25	30	3.6	50	60	75	90	100	120	150	180		
电动机/减速器 Motor/Gearhead	转速Speed r/min	50Hz	500	417	300	250	200	166	120	100	83	60	50	417	30	25	20	16	15	12	10	8	
	60Hz	600	500	360	300	240	200	144	120	100	72	60	500	36	30	24	20	18	15	12	10		
6IK140GU-AF□ 6IK140GU-EF□ 6IK140GU-CF□ 6IK140GU-HF□ 6IK140GU-SF□	容许力矩 Allowance Torque	50Hz	6GU□RC	1.99	2.39	3.31	3.98	4.97	6.63	9.21	11.0	13.3	18.4	22.1	26.5	33.1	39.8	49.7	59.6	60.0	60.0	60.0	
			6GU□RT	20.3	24.3	33.8	40.6	50.7	67.6	93.9	113	135	188	225	271	338	406	507	600	600	600	600	
		60Hz	6GU□RC	1.60	1.92	2.67	3.21	4.01	5.34	7.42	8.91	10.7	14.8	17.8	21.4	26.7	32.1	40.1	48.1	53.4	60.0	60.0	60.0
			6GU□RT	16.4	19.6	27.3	32.7	40.9	54.5	75.8	90.9	109	152	182	218	273	327	409	491	545	600	600	600

■ 感应尺寸图 Induction Type Drawing

6IK140GU-AF□/6GU□RC	6IK140GU-CF□/6GU□RC	5IK140GU-SF□/6GU□RC	6IK140GU-AF□/6GU□RT	6IK140GU-CF□/6GU□RT	5IK140GU-SF□/6GU□RT
6IK140GU-EF□/6GU□RC	6IK140GU-HF□/6GU□RC		6IK140GU-EF□/6GU□RT	6IK140GU-HF□/6GU□RT	

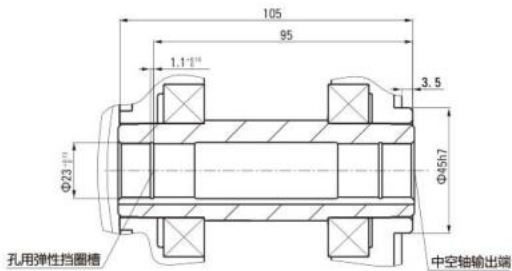
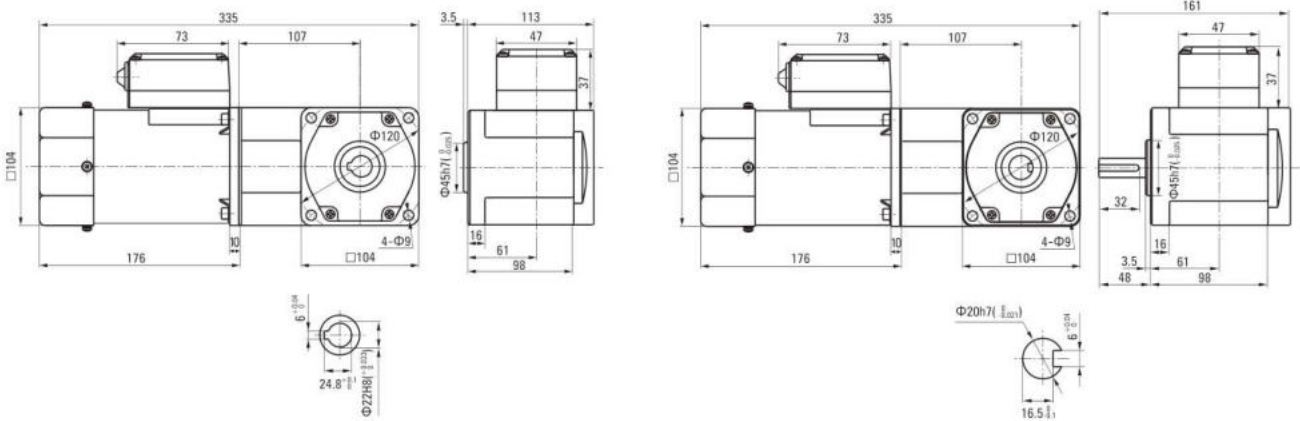

连接图 Wiring Diagram

- 运转方向指从电动机轴看来的方向。CW表示顺时针方向，CCW表示逆时针方向。

The direction of motor rotation is as viewed from the shaft end of motor. CW represents the clockwise direction, while CCW represents the counterclockwise direction.

- 表中所记品名为齿轮轴型，圆轴型亦同。

Name indicated in the list is pinion shaft type, also valid for the equivalent round shaft type.

导线型 Lead Wire Type		
6IK140GU-AF、6IK140GU-EF、6IK140GU-HF、6IK140GU-CF		6IK140GU-SF
<p>顺时针方向CW</p> <p>电容器 Capacitance</p>	<p>逆时针方向CCW</p> <p>电容器 Capacitance</p>	<p>顺时针方向CW</p> <p>逆时针方向CCW 若对换R、S、T中任意二条，电动机会作逆时针方向运转 To change the rotation direction change any two connections among R, S and T</p>
带端子箱型 Terminal Box Type		
6IK140GU-AFT、6IK140GU-EFT、6IK140GU-HFT、6IK140GU-CFT		6IK140GU-SFT
<p>顺时针方向CW</p> <p>电容器 Capacitance</p>	<p>逆时针方向CCW</p> <p>电容器 Capacitance</p>	<p>顺时针方向CW</p> <p>逆时针方向CCW 若对换U、V、W中任意二条，电动机会作逆时针方向运转 To change the rotation direction change any two connections among U, V and W</p>

请注意 Note:

单相电动机运转方向的转换应在电动机停止后进行。

Change the direction of single-phase motor rotation only after bring the motor to a stop.

若在电动机运转时转换运转方向，可能发生无法转换运转方向或须费时较久的情况。

If an attempt is made to change the direction of rotation while the motor is rotating, motor may ignore reversing command or change its direction of rotation after some delay.

感应电动机 INDUCTION MOTORS

■ 200W □ 104mm



规格 Specs 连续额定 Continuous Rating

型号 Model · 类型 Type 上段:齿轮轴 Upper:Pinion Shaft 下段()内:圆轴 Below:Round Shaft		输出功率 Output power W	电压 Voltage V	频率 Frequency Hz	电流 Current A	启动转矩 Starting Torque mN.m	额定转矩 Rated Torque mN.m	额定转速 Rated Speed r/min	电容器容量 Capacitor μF
导线型 Lead Wire Type 外形图Dimensions①	带端子箱型 Terminal Box Type 外形图Dimensions②								
6IK200GU-AF (6IK200A-AF)	6IK200GU-AFT (6IK200A-AFT)	200	1ph 100	50	3.2	900	1520	1250	45.0
				60	3.5		1230	1550	
6IK200GU-EF (6IK200A-EF)	6IK200GU-EFT (6IK200A-EFT)	200	1ph 110	60	2.75	850	1230	1550	35.0
			1ph 120		2.65				
6IK200GU-CF (6IK200A-CF)	6IK200GU-CFT (6IK200A-CFT)	200	1ph 220	50	1.40	1000	1520	1250	10.0
			1ph 230						
6IK200GU-HF (6IK200A-HF)	6IK200GU-HFT (6IK200A-HFT)	200	1ph 220	60	1.40	900	1230	1550	
			1ph 230						
6IK200GU-SF (6IK200A-SF)	6IK200GU-SFT (6IK200A-SFT)	200	3ph 220	50	1.20	3400	1520	1250	
				60	1.0				

- 各种安全规格以电动机铭牌上的型号名取得认证。
When the motor is approved under various safety standards, the model name on the nameplate is the approved model name.
- 注：“-A”型号中电压为110V时，配置电容器容量以实际铭牌为准。
Note:“-A” it means the voltage 110v,the assembly capacitor vaule it is according the labe.

种类 Type

● 电动机 Motor

机型 Type	型号 Model	
	齿轮轴型 Pinion Shaft	圆轴型 Round Shaft
导线型 Lead Wire Type	6IK200GU-AF	6IK200A-AF
	6IK200GU-EF	6IK200A-EF
	6IK200GU-CF	6IK200A-CF
	6IK200GU-HF	6IK200A-HF
	6IK200GU-SF	6IK200A-SF
带端子箱型 Terminal Box Type	6IK200GU-AFT	6IK200A-AFT
	6IK200GU-EFT	6IK200A-EFT
	6IK200GU-CFT	6IK200A-CFT
	6IK200GU-HFT	6IK200A-HFT
	6IK200GU-SFT	6IK200A-SFT

● 平行轴减速器（另售） Parallel Shaft Gearhead (Sold Separately)

减速器种类 Gearhead Type	减速器型号 Gearhead Model	减速比 Gear Ratio
长寿命●低噪音 Long Life ● Low Noise	6GU□K	3、3.6、5、6、7.5、9、 12.5、15、18、25、30、 36、50、60、75、90、 100、120、150、180、200

- 减速器型号的□中为减速比的数值
Enter the gear ratio in the box (□) within the model name

■ 装有减速器时的容许转矩 Gear Motor-Torque Table

- 减速器另售·中间减速器另售。电动机型号的□中为表示带端子箱型的记号(T)。
Gearhead and mid-gearbox can be sold separately. Enter the code that represents the terminal box type (T) in the box (□) within the model name.
- 减速品型号的□中为减速比的数值。
Enter the gear ratio in the box(□) within the model name.
- □色表示与电动机同一方向运转，其他则为相反方向。
The colored background □ indicates the same rotating direction of the motor while the rotating direction of others are opposite.
- 转速是以电动机的同步转速 (50Hz : 1500r/min、60Hz : 1800r/min) 为基准除以减速比而算出来的数值。实际转速将随负载大小变化所示数值减少2%~20%左右。
The speed is calculated by dividing the motor's synchronous speed(50Hz : 1500r/min、60Hz : 1800r/min) by the gear ratio. The actual speed is 2%~20% less than the displayed value, depending on the size of the load.
- 希望以大于下表的减速比进行进一步减速时，可在电动机与减速机之间安装减速比为10的中间减速机。这时的容许转矩为20N·m。
To reduce the speed beyond the gear ratio in the table, attach a decimal gearhead(gear ratio:10)between the gearhead and motor. In that case, the permissible torque is 20N·m.

■ 容许力矩单位 Allowance Torque Unit : 上段 Upside (N.m) /下段 Belowside (kgf.cm)

类型 Type 电动机/减速机 Motor/Gearhead	减速比 Gear Ratio		3	3.6	5	6	7.5	9	12.5	15	18	25	30	36	50	60	75	90	100	120	150	180	200
	转速 Speed r/min	50Hz	500	417	300	250	200	166	120	100	83	60	50	42	30	25	20	16	15	12.5	10	8.3	7.5
		60Hz	600	500	360	300	240	200	144	120	100	72	60	50	36	30	24	20	18	15	12	10	9
6IK200GU-AF□	6GU□K	50Hz	3.71	4.46	6.19	7.43	9.28	11.1	13.9	16.7	20.1	25.2	30.3	36.3	40	40	40	40	40	40	40	40	40
6IK200GU-EF□		60Hz	37.9	45.5	63.1	75.8	94.7	114	142	171	205	257	309	370	400	400	400	400	400	400	400	400	400
6IK200GU-CF□		50Hz	2.99	3.59	4.99	5.99	7.49	8.98	11.2	13.5	16.2	20.3	24.4	29.3	40	40	40	40	40	40	40	40	40
6IK200GU-HF□		60Hz	30.6	36.7	50.9	61.1	76.4	91.7	115	138	165	207	249	299	400	400	400	400	400	400	400	400	400
6IK200GU-SF□																							

■ 容许悬挂负载 · 容许轴向负载 To Allow The Hoisting Of The Load Allow Axial Load

电动机 (圆轴型) →P272页 Motor(Round Shaft) →P272
减速机→272页 Gearhead→P272

■ 减速机的容许负载惯性惯量 J Permissible Load Inertia J For Gearhead

→272页→P272

■ 外形图 (单位 mm) Dimensions(Unit mm)

减速机附有安装用螺丝 Mounting screws are included with gearhead.

● 导线型 Lead Wiring Type ①

重量 Weight : 电动机 Motor : 5.0kg 减速机 Gearhead : 2.1kg

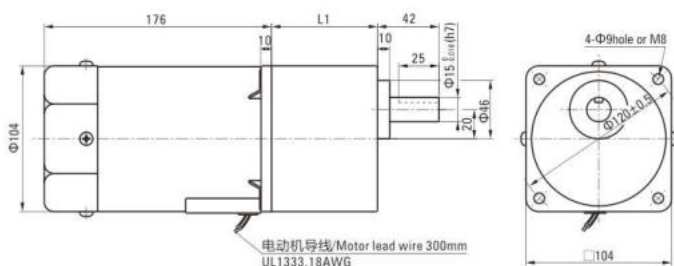

电动机型号 Motor Model	减速机型号 Gearhead Model	减速比 Gear Ratio	L1
6IK200GU-AF	6GU□K	3~200	72
6IK200GU-EF			
6IK200GU-CF			
6IK200GU-HF			
6IK200GU-SF			

- 减速机型号的□中为减速比的数值
Enter the gear ratio in the box (□) within the model name

● 带端子箱型 Terminal Box Type ②

重量 Weight : 电动机 Motor : 5.15kg

减速器 Gearhead : 2.1kg

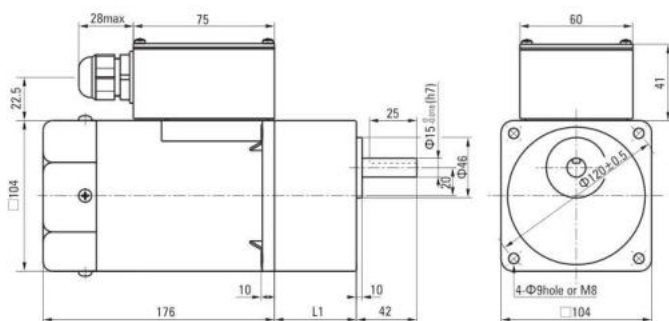

● 适用电缆直径为 Use cable with a diameter of $\Phi 6 \sim \Phi 12\text{mm}$

● 圆轴型的转轴部分 Shaft Section Of Round Shaft Type

除重量及轴部外电动机外形与齿轮轴型相同。

Excluding weight and the shaft section motor shape are the same as those of the pinion shaft type.

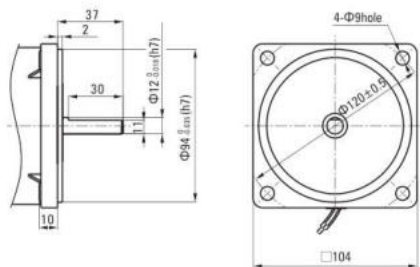

■ 电容器外形尺寸 Formal Dimension Of Capacitor

型号 Model		电容器型号 Capacitor Model	L	W	H
齿轮轴型 Pinion Shaft	圆轴型 Round Shaft				
6IK200GU-AF	6IK200A-AF	ZD450CFAUL	70	38	52
6IK200GU-EF	6IK200A-EF	ZD350CFAUL	58	30	40
6IK200GU-CF	6IK200A-CF	ZD100BFAUL	58	26	38

● 常规电容器出线为引线,也可根据客户要求配置插片式187#

Note: Conventional capacitor is a lead wire type. Inserted 187# is optional

● 电动机型号的□中为表示带端子箱型的记号(T)

Enter the code that represents the terminal box type (T) in the box (□) within the model name

电动机型号 Motor Model	减速器型号 Gearhead Model	减速比 Gear Ratio	L1
6IK200GU-AFT	6GU□K	3~200	72
6IK200GU-EFT			
6IK200GU-CFT			
6IK200GU-HFT			
6IK200GU-SFT			

● 减速器型号的□中为减速比的数值

Enter the gear ratio in the box (□) within the model name

● 键·键槽 (减速器附件)

Key · Keyway (Accessory Of Gearhead)

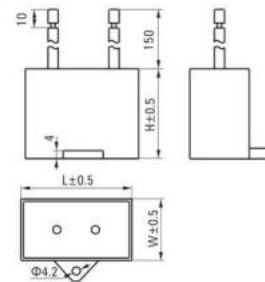
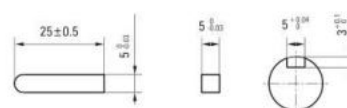

弧锥直角 SPIRAL BEVEL RIGHT ANGLE

■ 装有减速器时的容许转矩 Gear Motor-Torque Table

- 减速器 中间减速器另售。 • 电动机型号的□中为表示带端子箱型的记号(T)。
Gearhead and mid-gearbox can be sold separately. Enter the code that represents the terminal box type (T) in the box (□) within the model name.
- 减速器型号的□中为减速比的数值。 □ 色表示与电动机同一方向运转，其他则为相反方向。
Enter the gear ratio in the box (□) within the model name.
The colored background □ indicates the same rotating direction of the motor while the rotating direction of others are opposite.
- 转速是以电动机的同步转速 (50Hz:1500r/min、60Hz:1800r/min) 为基准除以减速比而算出来的数值。实际转速将随负载大小变化而比所示数值减少2%~20%左右。
The speed is calculated by dividing the motor's synchronous speed (50Hz:1500r/min、60Hz:1800r/min) by the gear ratio. The actual speed is 2%~20% less than the displayed value, depending on the size of the load.
- 希望以大于下表的减速比进行进一步减速时，这时的容许转矩为60N·m。
To reduce the speed beyond the gear ratio in the table, In that case, the permissible torque is 60N·m.

■ 容许力矩单位 Allowance Torque Unit: 上段 Upside (N.m) / 下段 Belowside (kgf.cm)

机型Type 电动机/减速器 Motor/Gearhead	减速比Gear Ratio	容许力矩 Allowance Torque																				
		3	3.6	5	6	7.5	9	12.5	15	18	25	30	36	50	60	75	90	100	120	150	180	
6IK200GU-AF□ 6IK200GU-EF□ 6IK200GU-CF□ 6IK200GU-HF□ 6IK200GU-SF□	6GU□RC 6GU□RT	50Hz	500	417	300	250	200	166	120	100	83	60	50	42	30	25	20	16	15	12	10	8
		60Hz	600	500	360	300	240	200	144	120	100	72	60	50	36	30	24	20	18	15	12	10
6IK200GU-AF□ 6IK200GU-EF□ 6IK200GU-CF□ 6IK200GU-HF□ 6IK200GU-SF□	6GU□RC 6GU□RT	50Hz	3.71	4.46	6.19	7.43	9.28	11.1	13.9	16.7	20.1	25.2	30.3	36.3	50.4	60.0	60.0	60.0	60.0	60.0	60.0	60.0
		60Hz	2.99	3.59	4.99	5.99	7.49	8.98	11.2	13.5	16.2	20.3	24.4	29.3	40.7	48.8	60.0	60.0	60.0	60.0	60.0	60.0
6IK200GU-AF□ 6IK200GU-EF□ 6IK200GU-CF□ 6IK200GU-HF□ 6IK200GU-SF□	6GU□RC 6GU□RT	50Hz	37.9	45.5	63.1	75.8	94.7	114	142	171	205	257	30.9	370	515	600	600	600	600	600	600	600
		60Hz	2.99	3.59	4.99	5.99	7.49	8.98	11.2	13.5	16.2	20.3	24.4	29.3	40.7	48.8	60.0	60.0	60.0	60.0	60.0	60.0

■ 感应、可逆尺寸图 Induction, Reversible Type Drawing

6IK200GU-AF□/6GU□RC 6IK200GU-EF□/6GU□RC	6IK200GU-CF/6GU□RC 6IK200GU-HF/6GU□RC	6IK200GU-SF□/6GU□RC	6IK200GU-AF□/6GU□RT 6IK200GU-EF□/6GU□RT	6IK200GU-CF/6GU□RT 6IK200GU-HF/6GU□RT	6IK200GU-SF□/6GU□RT
--	--	---------------------	--	--	---------------------

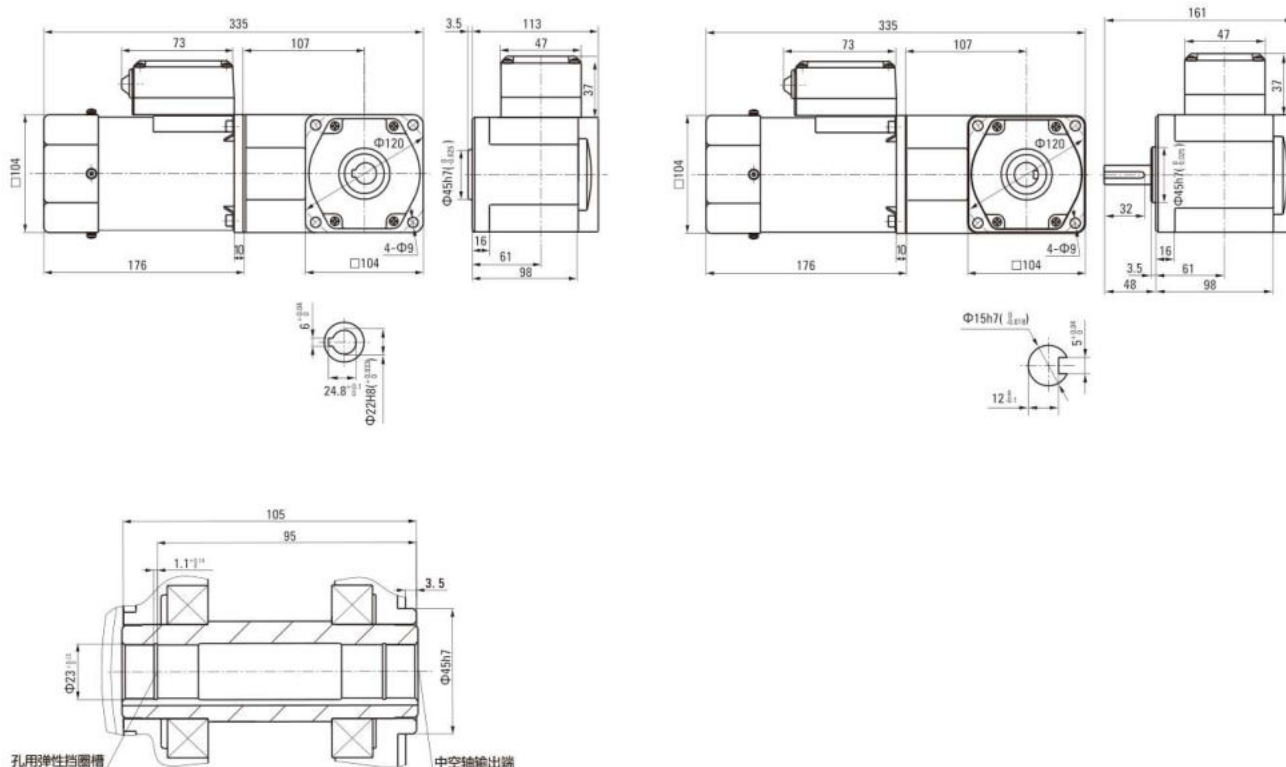

■ 连接图 Wiring Diagram

- 运转方向指从电动机轴看来的方向。CW表示顺时针方向，CCW表示逆时针方向。

The direction of motor rotation is as viewed from the shaft end of motor. CW represents the clockwise direction, while CCW represents the counterclockwise direction.

- 表中所记品名为齿轮轴型，圆轴型亦同。

Name indicated in the list is pinion shaft type, also valid for the equivalent round shaft type.

导线型 Lead Wire Type		
6IK200GU-AF、6IK200GU-EF、6IK200GU-HF、6IK200GU-CF		6IK200GU-SF
顺时针方向CW 	逆时针方向CCW 	顺时针方向CW 逆时针方向CCW 若对换R、S、T中任意二条，电动机作逆时针方向运转 To change the rotation direction change any two connections among R, S and T
带端子箱型 Terminal Box Type		
6IK200GU-AFT、6IK200GU-EFT、6IK200GU-HFT、6IK200GU-CFT		6IK200GU-SFT
顺时针方向CW 	逆时针方向CCW 	顺时针方向CW 逆时针方向CCW 若对换U、V、W中任意二条，电动机作逆时针方向运转 To change the rotation direction change any two connections among U, V and W

请注意 Note:

单相电动机运转方向的转换应在电动机停止后进行。

Change the direction of single-phase motor rotation only after bring the motor to a stop.

若在电动机运转时转换运转方向，可能发生无法转换运转方向或须费时较久的情况。

If an attempt is made to change the direction of rotation while the motor is rotating, motor may ignore reversing command or change its direction of rotation after some delay.

感应电动机 2极·高速型 INDUCTION MOTOR 2-POLES·HIGH SPEED

■ 6W~150W □ 60mm · □ 70mm · □ 80mm · □ 90mm



规格 Specs 连续额定 Continuous Rating

型号Model · 类型 Type 圆轴型 Round Shaft Type	输出功率 Output power W	电压 Voltage V	频率 Frequency	电流 Current	启动转矩 Starting Torque mN.m	额定转矩 Rated Torque mN.m	额定转速 Rated Speed r/min	电容器容量 Capacitor μF
			Hz	A				
2IK6A-B	6	1ph 110	50	0.18	35	22	2650	3
			60	0.20		18	3100	
2IK6A-D	6	1ph 220	50	0.11	35	22	2650	0.8
			60	0.12		18	3100	
3IK15A-B	15	1ph 110	50	0.38	65	54	2650	6
			60	0.40		46	3100	
3IK15A-D	15	1ph 220	50	0.18	65	54	2650	1.5
			60	0.22		46	3100	
4IK25A-B	25	1ph 110	50	0.55	90	90	2650	10
			60	0.65		77	3100	
4IK25A-D	25	1ph 220	50	0.25	90	90	2650	2
			60	0.30		77	3100	
4IK25A-T	25	1ph 220	50	0.20	220	88	2700	-
			60	0.15	185	75	3200	
4IK40A-BF	40	1ph 110	50	0.80	120	147	2600	12
			60	0.85		123	3100	
4IK40A-DF	40	1ph 220	50	0.40	120	147	2600	3
			60	0.45		123	3100	
4IK40A-TF	40	1ph 220	50	0.27	350	147	2600	-
			60	0.22	300	123	3100	
5IK40A-B	40	1ph 110	50	0.75	140	147	2600	10
			60	0.90		123	3100	
5IK40A-D	40	1ph 220	50	0.38	140	144	2650	3
			60	0.40		120	3200	
5IK40A-T	40	1ph 220	50	0.26	350	147	2600	-
			60	0.21	300	123	3100	
5IK60A-BF	60	1ph 110	50	1.05	170	215	2650	15
			60	1.0		180	3200	
5IK60A-DF	60	1ph 220	50	0.52	180	215	2650	4
			60	0.55		180	3200	
5IK60A-TF	60	1ph 220	50	0.35	500	215	2650	-
			60	0.30	420	180	3200	

规格 Specs 连续额定 Continuous Rating

型号 Model · 类型 Type 圆轴型 Round Shaft Type	输出功率 Output power W	电压 Voltage V	频率 Frequency Hz	电流 Current A	启动转矩 Starting Torque mN.m	额定转矩 Rated Torque mN.m	额定转速 Rated Speed r/min	电容器容量 Capacitor μF
5IK90A-BF	90	1ph 110	50	1.50	250	325	2650	25
			60	1.80		270	3200	
5IK90A-DF	90	1ph 220	50	0.72	250	325	2650	6
			60	0.90		270	3200	
5IK90A-TF 5IK90A-TFT	90	3ph 220	50	0.50	800	325	2650	-
			60	0.42	670	270	3200	
5IK120A-BF	120	1ph 110	50	1.85	330	450	2650	30
			60	2.25		360	3200	
5IK120A-DF	120	1ph 220	50	0.95	330	450	2650	8
			60	1.10		360	3200	
5IK120A-TE 5IK120A-TFT	120	3ph 220	50	0.65	1000	430	2650	-
			60	0.50	900	370	3100	
5IK150A-BF	150	1ph 110	50	2.50	400	540	2650	35
			60	2.85		450	3200	
5IK150A-DF	150	1ph 220	50	1.20	400	540	2650	10
			60	1.52		450	3200	
5IK150A-TF 5IK150A-TFT	150	3ph 220	50	0.85	1250	550	2600	-
			60	0.70	1100	460	3100	

种类 Type

电动机 Motor

输出功率 Output power	电压 Voltage	型号 Model
6W	1ph110VAC	2IK6A-B
	1ph220VAC	2IK6A-D
15W	1ph110VAC	3IK15A-B
	1ph220VAC	3IK15A-D
25W	1ph110VAC	4IK25A-B
	1ph220VAC	4IK25A-D
	3ph220VAC	4IK25A-T
40W	1ph110VAC	4IK40A-BF
	1ph220VAC	4IK40A-DF
	3ph220VAC	4IK40A-T
40W	1ph110VAC	5IK40A-B
	1ph220VAC	5IK40A-D
	3ph220VAC	5IK40A-T
60W	1ph110VAC	5IK60A-BF
	1ph220VAC	5IK60A-DF
	3ph220VAC	5IK60A-TF
	3ph220VAC	5IK60A-TFT

输出功率 Output power	电压 Voltage	型号 Model
90W	1ph110VAC	5IK90A-BF
	1ph220VAC	5IK90A-DF
	3ph220VAC	5IK90A-TF
	3ph220VAC	5IK90A-TFT
120W	1ph110VAC	5IK120A-BF
	1ph220VAC	5IK120A-DF
	3ph220VAC	5IK120A-TF
150W	3ph220VAC	5IK120A-TFT
	1ph110VAC	5IK150A-BF
	1ph220VAC	5IK150A-DF
	3ph220VAC	5IK150A-TF
	3ph220VAC	5IK150A-TFT

■外形图 (单位 mm) Dimensions(Unit mm)

● 6W

电动机 Motor
2IK6A-B、2IK6A-D
重量Weight: 0.65kg

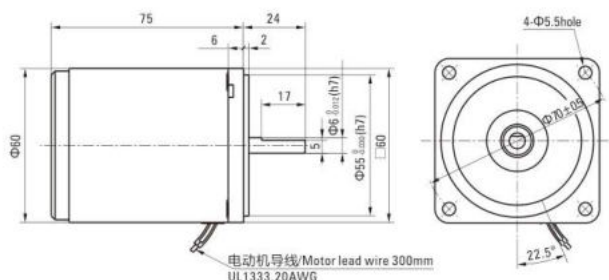

■外形图 (单位 mm) Dimensions(Unit mm)

● 15W

电动机 Motor
3IK15A-B、3IK15A-D
重量Weight: 0.90kg

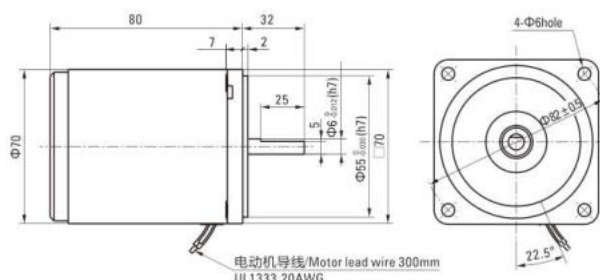

■外形图 (单位 mm) Dimensions(Unit mm)

● 25W

电动机 Motor
4IK25A-B、4IK25A-D、4IK25A-T
重量Weight: 1.4kg

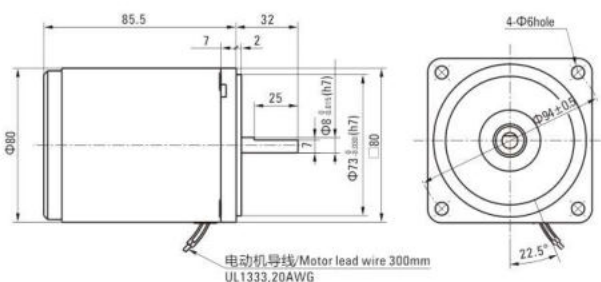

■外形图 (单位 mm) Dimensions(Unit mm)

● 40W

电动机 Motor
4IK40A-BF、4IK40A-DF、4IK40A-TF
重量Weight: 1.6kg

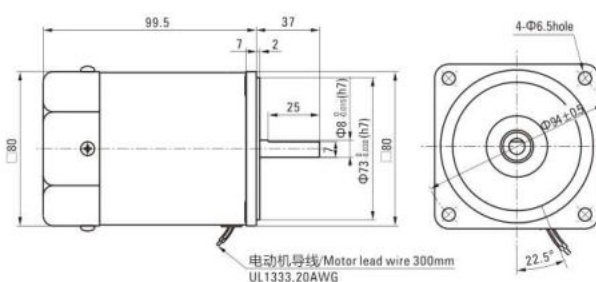

■外形图 (单位 mm) Dimensions(Unit mm)

● 40W

电动机 Motor
5IK40A-B、5IK40A-D、5IK40A-T
重量Weight: 2.0kg

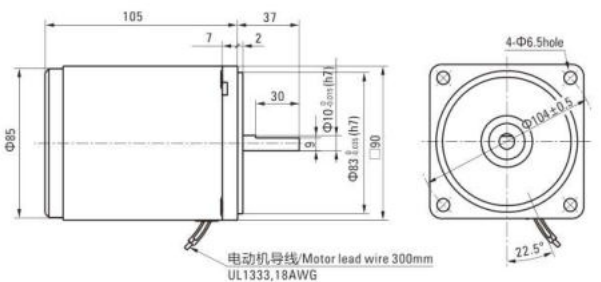

■外形图 (单位 mm) Dimensions(Unit mm)

● 60W

电动机 Motor
5IK60A-BF、5IK60A-DF、5IK60A-TF
重量Weight: 2.4kg

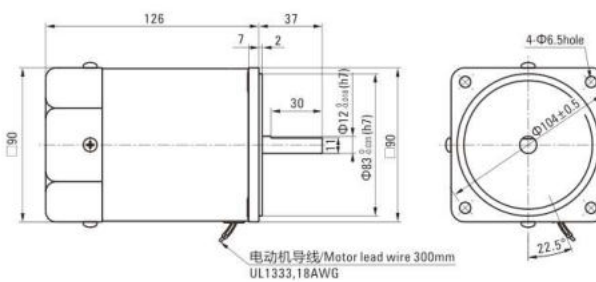

■外形图 (单位 mm) Dimensions(Unit mm)

● 90W

电动机 Motor

5IK90A-BF、5IK90A-DF、5IK90A-TF

重量Weight: 2.8kg

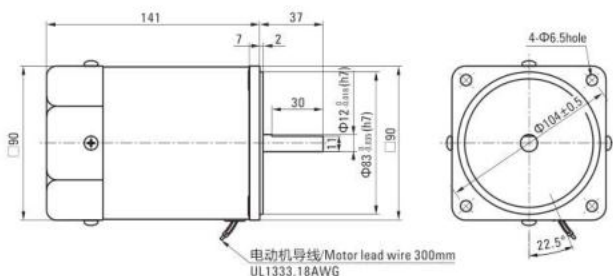

■外形图 (单位 mm) Dimensions(Unit mm)

● 120W

电动机 Motor

5IK120A-BF、5IK120A-DF、5IK120A-TF

5IK150A-BF、5IK150A-DF、5IK150A-TF

重量Weight: 0.90kg

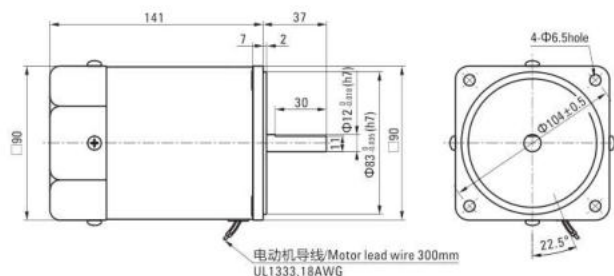

■外形图 (单位 mm) Dimensions(Unit mm)

● 90W、120W、150W

电动机 Motor

5IK90A-TFT、5IK120A-TFT、5IK150A-TFT

重量Weight: 3.3kg

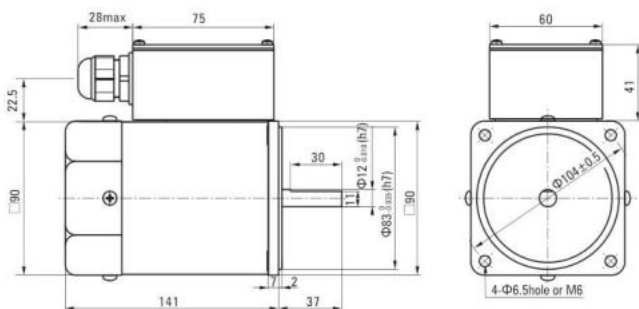

■电容器外形尺寸 Formal Dimension of Capacitor

型号Model	电容器型号 Capacitor Model	L	W	H
2IK6A-B	ZD30CFAUL	38	18.5	29
2IK6A-D	ZD08BFAUL	36	10.5	20
3IK15A-B	ZD60CFAUL	48	23	32
3IK15A-D	ZD15BFAUL	36	12.5	24
4IK25A-B	ZD100CFAUL	38	19.5	31
4IK25A-D	ZD20BFAUL	36	15	25
4IK40A-BF	ZD120CFAUL	58	30	40
5IK40A-DF	ZD30BFAUL	38	18.5	29
5IK40A-B	ZD100CFAUL	58	26	38
5IK40A-D	ZD30BFAUL	38	18.5	29
5IK60A-BF	ZD150CFAUL	47	20	31
5IK60A-DF	ZD40BFAUL	47	17	31
5IK90A-BF	ZD250CFAUL	47	27	37
5IK90A-DF	ZD60BFAUL	48	23	32
5IK120A-BF	ZD300CFAUL	58	26	38
5IK120A-DF	ZD80BFAUL	40	26.5	38
5IK150A-BF	ZD350CFAUL	58	30	40
5IK150A-DF	ZD100BFAUL	58	26	38

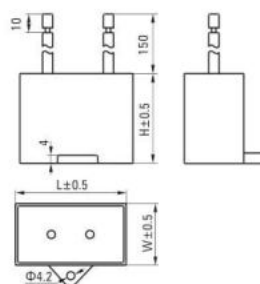

连接图 Wiring Diagram

●运转方向指从电动机轴看来方向。CW表示顺时针方向，CCW表示逆时针方向。

The direction of motor rotation is as viewed from the shaft end of motor. CW represents the clockwise direction, while CCW represents the counterclockwise direction.

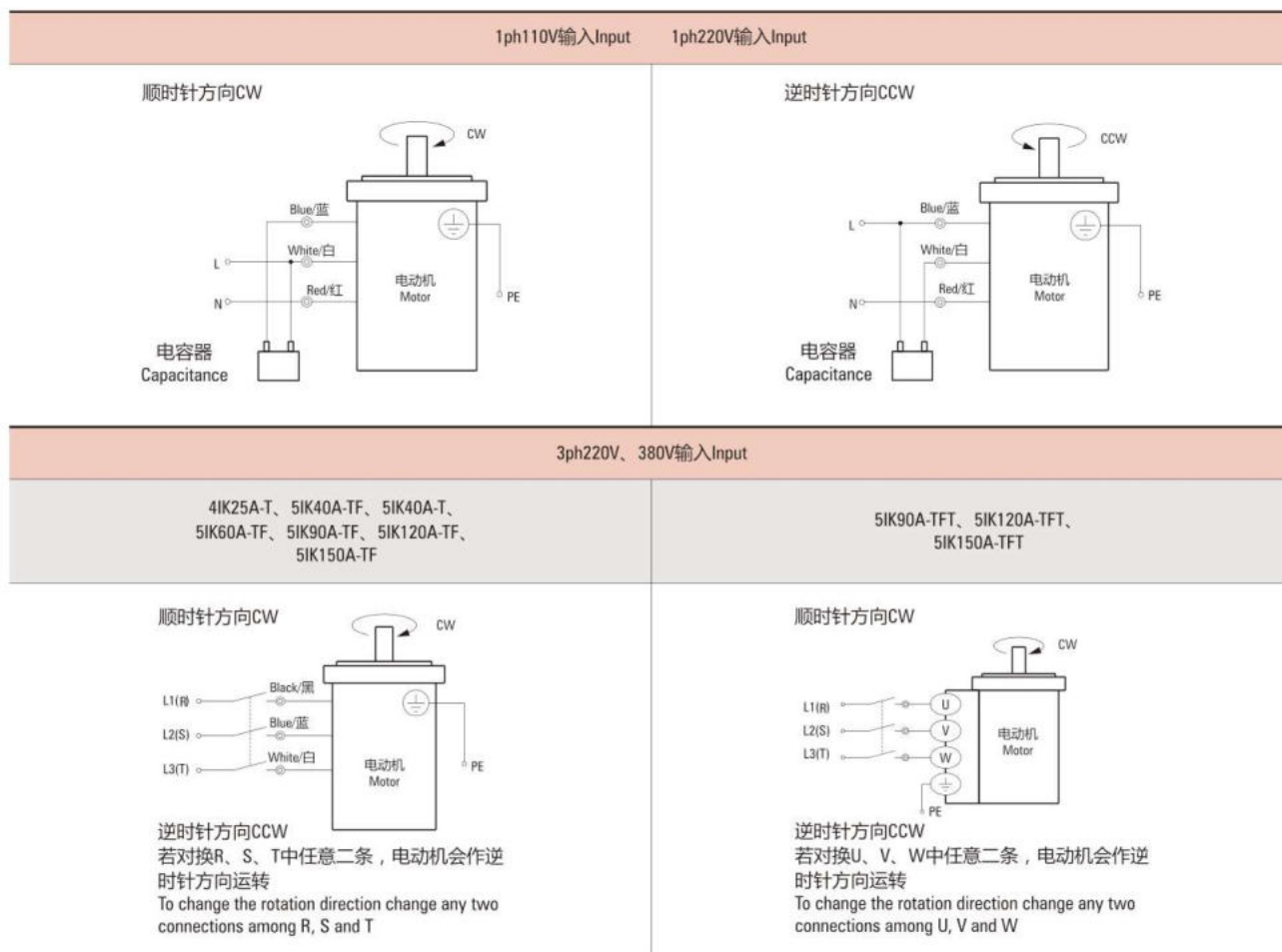



8 800 555-63-74 бесплатные звонки по РФ

Контакты

+7 (495) 505-63-74 - Москва

+7 (473) 204-51-56 - Воронеж

www.purelogic.ru

394033, Россия, г. Воронеж,
Ленинский пр-т, 160, офис 149

Пн-Чт: 8:00–17:00

Пт: 8:00–16:00

Перерыв: 12:30–13:30

info@purelogic.ru